

# Instrumentation

1. Introduction .....	2
2. Piping & Instrumentation Diagram (P&ID) .....	5
3. Pressure measurements .....	8
4. Temperature measurements .....	29
5. Level measurements .....	48
6. Flow measurements .....	65
7. Control Valves .....	84
8. Detection Device (Fire – Gas – Duct) .....	97
9. PID (Proportional Integral Derivative)	
10. ....	

## ① Introduction

- **Instrumentation:** To obtain final product with an economic and standard specification Via:

- Monitor
- Control
- Protection

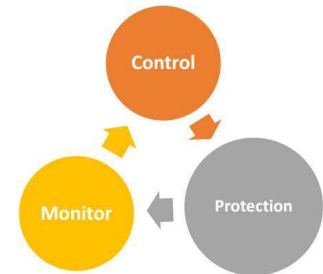

- **Automated control system:**

1) Sensors: (switch, transmitter, Gauge).

### TRANSMITTERS



ANALOGUE SIGNAL  
4 to 20 mA

### SWITCHES



DIGITAL SIGNAL  
0, 1

### GAUGES



NO SIGNAL

2) Controller: (PLC, DCS, PID).

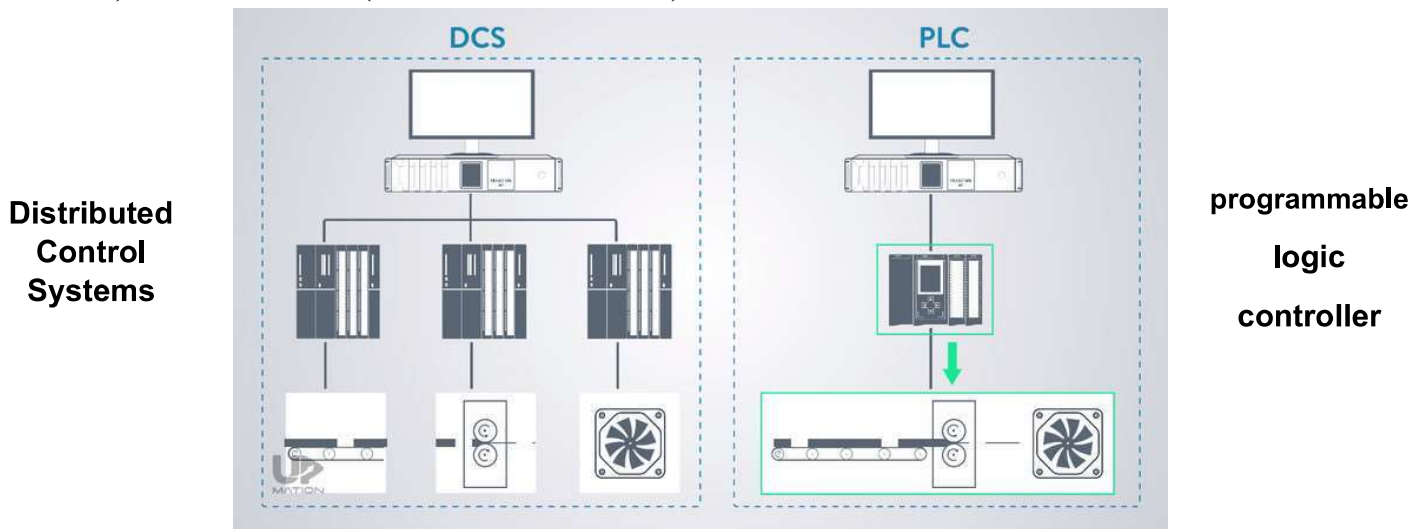

3) Final control element: (Pump, control Valve, Heater).

▪ Control Loop System:

1) Open loop control

Non feedback Control

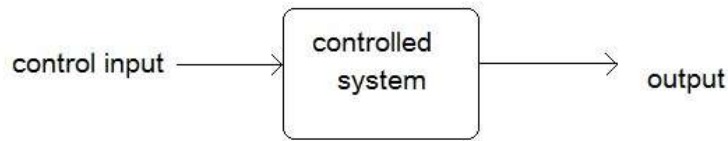

2) Closed loop control

With feedback element

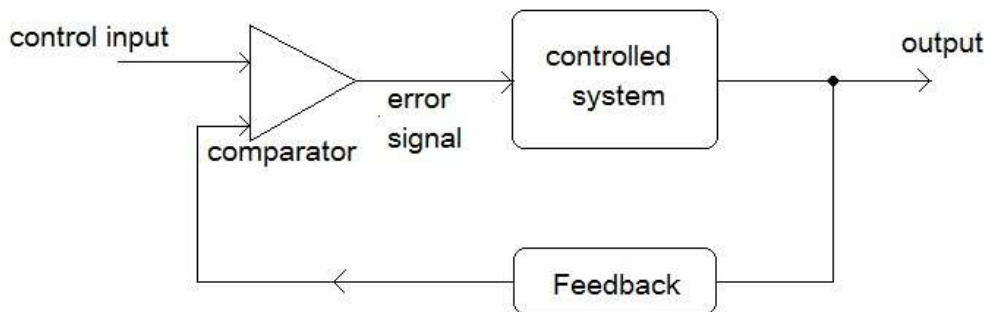

3) Cascade loop control

- Using two controllers (the first controller O/P providing the set point for the second).
- With two feedback element.

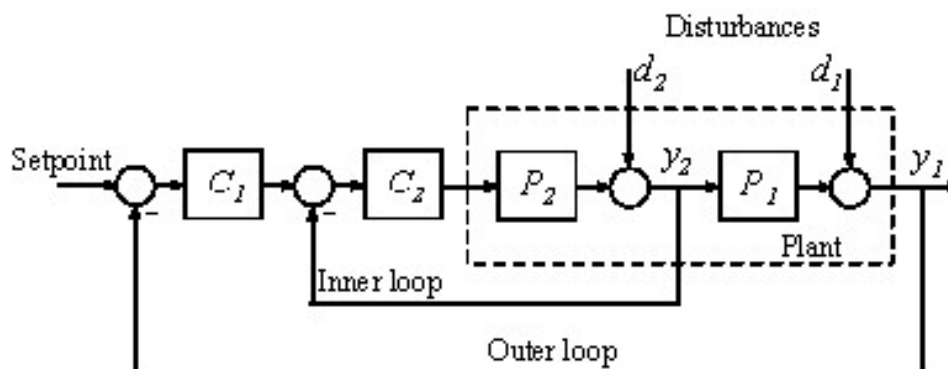

▪ Process Variables:

- 1) Physical: (pressure – Temperature – Level - Flow).
- 2) Chemical: (PH – Conductivity – Oil Detector).
- 3) Mechanical:( Vibration – Speed – Fraction).

Notes:

- PH: is the negative logarithm of the hydrogen ion activity, measure of how acidic/basic water is. The range goes from 0 to 14, with 7 being neutral. PH of less than 7 indicate **acidity**, whereas a PH of greater than 7 indicates a **base**.

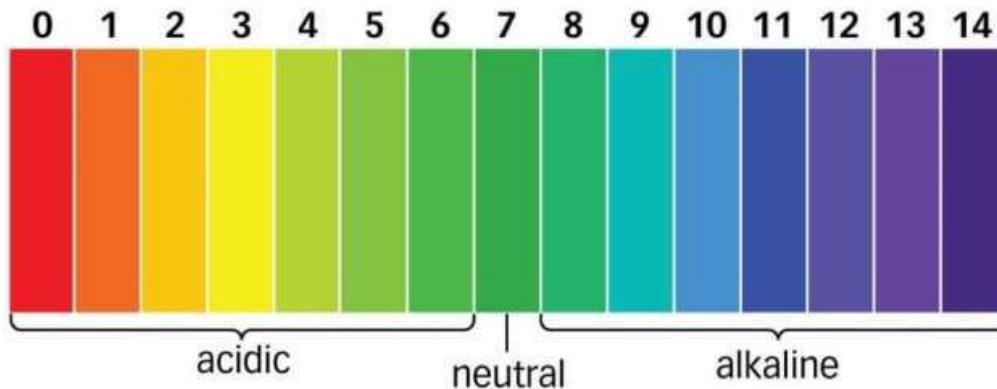

# water supplying the boiler ( PH = 9 : 10.5 & 0.05  $\mu\text{S}/\text{cm}$  )

- Conductivity: is a measure of its ability to conduct electricity. The SI unit of conductivity is Siemens per meter (S/m).  
# Sea water: 50,000  $\mu\text{S}/\text{cm}$   
# Raw water: 700 – 1000  $\mu\text{S}/\text{cm}$   
# TDS = conductivity \* 0.64 ( Total Dissolved Solid)
- Passive Device: Need external electrical current like (Resistance – Inductor – Capacitor).
- Transducer: change physical parameter to electrical parameter.
- Transmitter: change between electrical parameter to send it to controller.

## ② P & ID

# P&ID

Piping & Instrumentation Diagram  
**PROCESS & INSTRUMENTATION DIAGRAM**

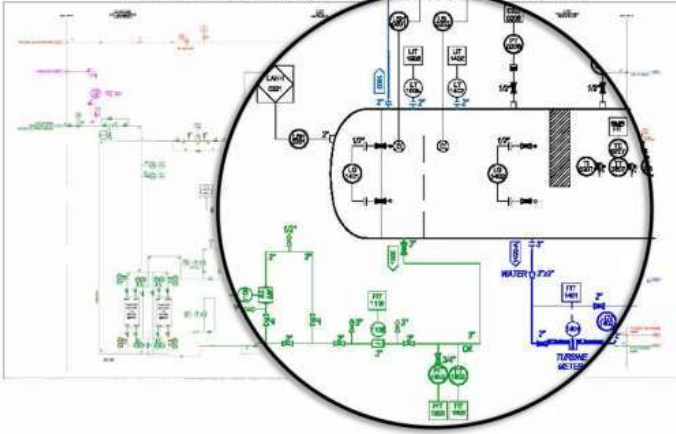

Complex & Detailed

# PFD

Process Flow Diagram

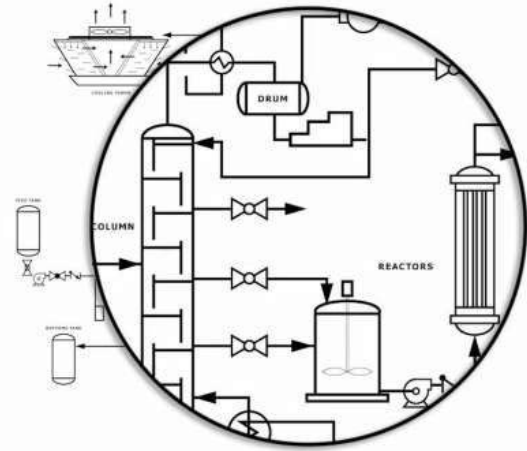

Simplified Overview of a Process

A diagram which shows the interconnection of process equipment and the instrumentation used to control the process. They usually contain the following information:

- Mechanical equipment, including:
  - Pressure vessels, columns, tanks, pumps, compressors, heat exchangers, furnaces, wellheads, fans, cooling towers, turbo-expanders
  - Bursting discs, restriction orifices, strainers and filters, steam traps, moisture traps, sight-glasses, silencers, flares and vents, flame arrestors, vortex breakers, eductors
- Process piping, sizes and identification, including:
  - Pipe classes and piping line numbers
  - Flow directions
  - Interconnections references
  - Permanent start-up, flush and bypass lines
- Process control instrumentation and designation (names, numbers, unique tag identifiers), including:
  - Valves and their types and identifications (e.g. isolation, shutoff, relief and safety valves, valve interlocks)
  - Control inputs and outputs (sensors and final elements, interlocks)
  - Miscellaneous - vents, drains, flanges, special fittings, sampling lines, reducers.

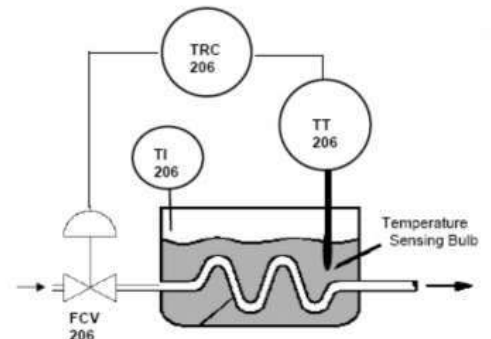
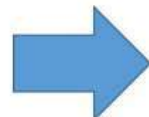
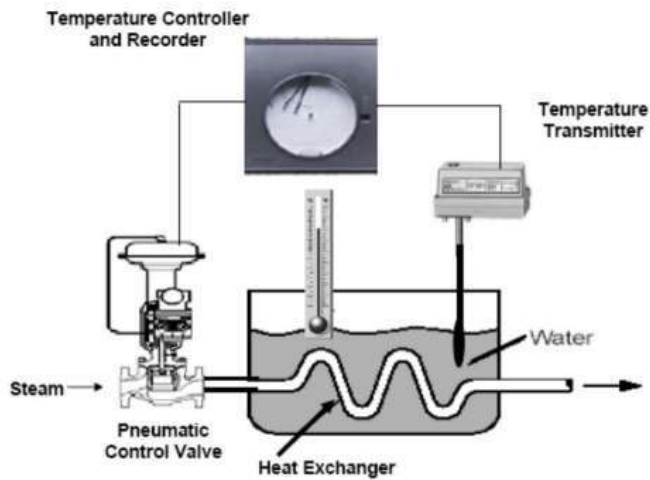

The first letter is used to designate the **measured variable**

The succeeding letter(s) are used to designate the **function** of the component, or to **modify** the meaning of the first letter.

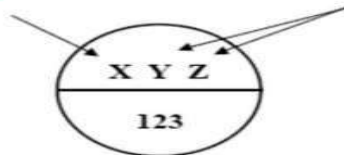

- P**ressure
- L**evel
- F**low
- T**emperature

- I**ndicator
- R**ecorder
- C**ontroller
- T**ransmitter

The presence or absence of a line determines the location of the physical device. For example **no line** means the instrument is installed in the field near the process.

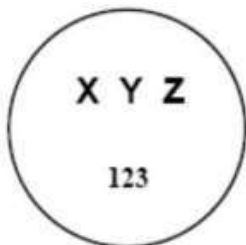

**No Line**

The instrument is mounted in the field near the process, (close to the operator)

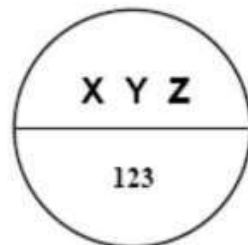

**Solid Line**

The instrument is mounted in the control room (accessible to the operator)

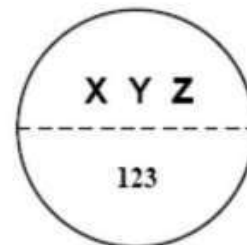

**No Line**

The instrument is mounted out of sight (not accessible to the operator)

Some instruments are part of a Distributed Control System (DCS) where a specific controller or indicator can be selected from many others but shown in one location (like a terminal screen)

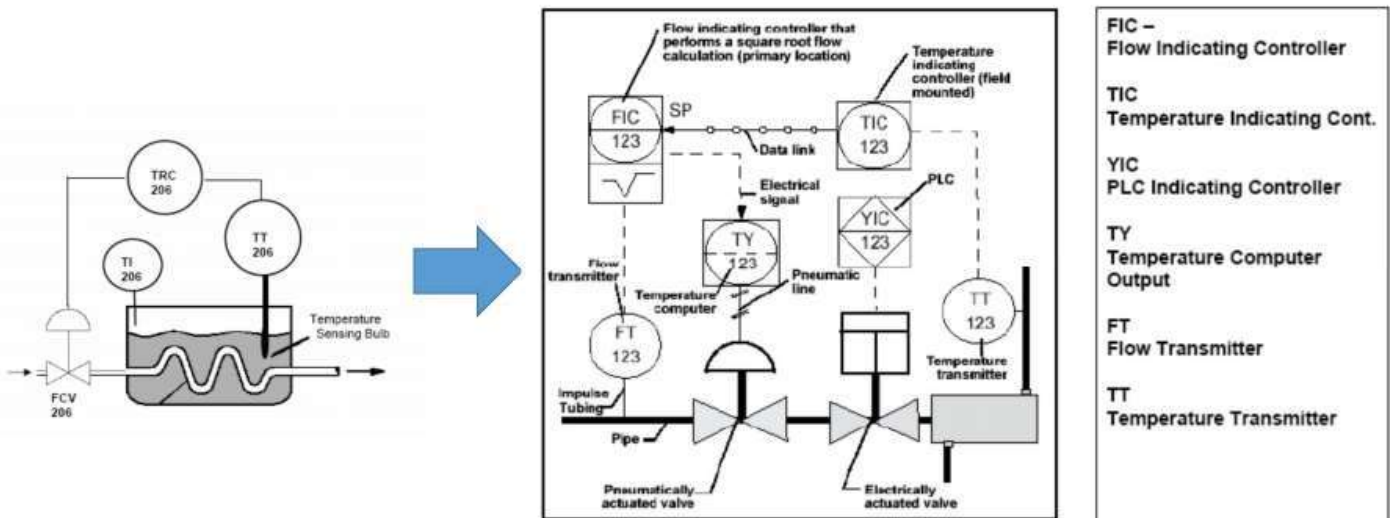
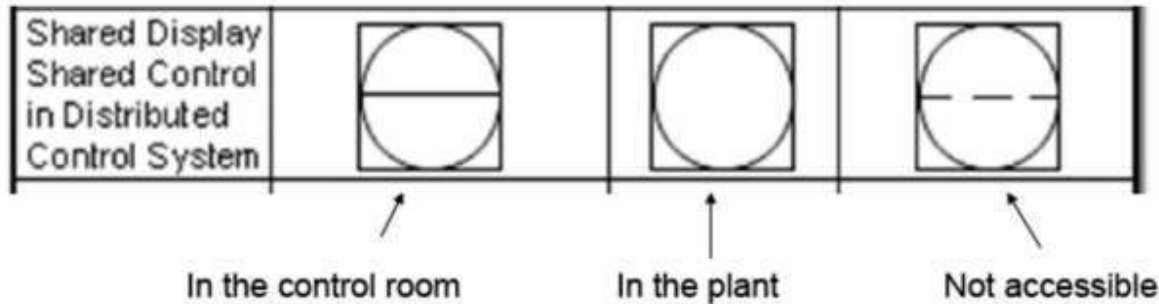

Process	Device	Device/Condition	Condition
Pressure	<b>P</b> Controller	<b>C</b> Controller	<b>C</b> High <b>H</b>
Temperature	<b>T</b> Transmitter	<b>T</b> Transmitter	<b>T</b> Low <b>L</b>
Level	<b>L</b> Recorder	<b>R</b> Recorder	<b>R</b>
Flow	<b>F</b> Indicator	<b>I</b> Valve	<b>V</b>
Analysis	<b>A</b> Alarm	<b>A</b> High	<b>H</b>
	Switch/Safety	<b>S</b> Low	<b>L</b>
	Gauge	<b>G</b>	

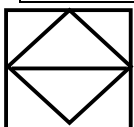

: PLC Symbol

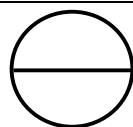

: Physical Instrument

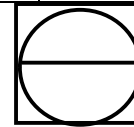

:DCS Symbol

### ③ Pressure Measurements

- $P = \frac{F}{A} = \rho gh$

To► From ▼	psi	mbar	bar	atm	Pa	kPa	MPa	mmH <sub>2</sub> O	in.H <sub>2</sub> O	mmHg	in.Hg	kg/cm <sup>2</sup>
psi	1	68.95	0.0689	0.0681	6895	6.895	0.006895	703.8	27.71	51.715	2.036	0.0704
mbar	0.0145	1	0.001	0.000967	100	0.100	0.0001	10.21	0.402	0.75	0.0295	0.00102
bar	14.504	1000	1	0.987	100000	100	0.1	10210	401.9	750.1	29.53	1.02
atm	14.7	1013.25	1.01325	1	101325	101.325	0.1013	10343	407.2	760.0	29.92	1.033
Pa	0.000145	0.01	0.00001	0.00001	1	0.001	0.000001	0.102	0.00402	0.0075	0.000295	0.00001
kPa	0.14504	10.0	0.01	0.00987	1000	1	0.001	102.07	4.019	7.5	0.295	0.0102
MPa	145.04	10000	10	9.87	1000000	1000	1	101971.6	4014.6	7500.6	295.3	10.2
mmH <sub>2</sub> O	0.001421	0.098	0.000098	0.000097	9.8	0.0098	0.0000098	1	0.0394	0.0735	0.00289	0.0001
in.H <sub>2</sub> O	0.0361	2.488	0.002488	0.00246	248.8	0.2488	0.00025	25.4	1	1.866	0.0735	0.00254
mmHg	0.01934	1.333	0.001333	0.001316	133.3	0.1333	0.00013	13.61	0.536	1	0.0394	0.00136
in.Hg	0.4912	33.86	0.03386	0.03342	3386	3.386	0.00386	345.7	13.61	25.4	1	0.0345
kg/cm <sup>2</sup>	14.22	980.7	0.9807	0.968	98067	98.067	0.0981	10010	394.1	735.6	28.96	1

- 1 Bar = 10<sup>5</sup> Pa = 14.7 PSI = 10200 mmH<sub>2</sub>O = 1.0193 Kg/cm<sup>2</sup>
- P (abs) = P(gauge) + P(atm)
- P(vacuum) = P(atm) - P(abs)

- PSI : Pound / inch<sup>2</sup>
- $\rho$  : Density in (kg/m<sup>3</sup>)
- $g$ : acceleration due to gravity (9.8 m/s<sup>2</sup>)
- $h$  : depth in liquid in (m)
- 1 Bar = 29.53 in.Hg
- **PSI A** = **PSI G** + 14.7

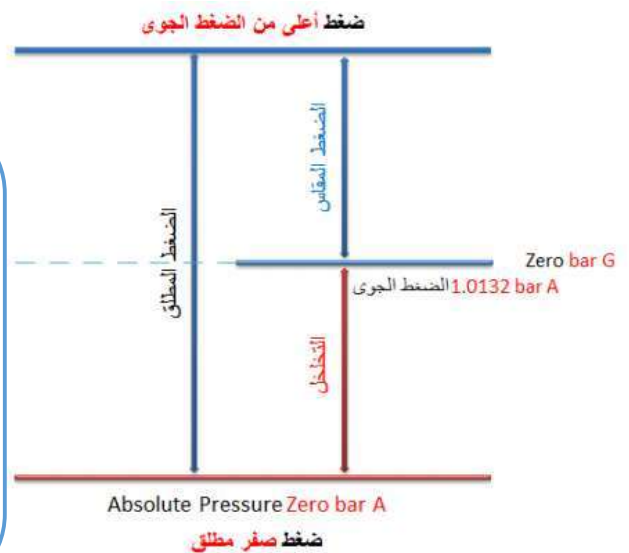

# Pressure Measurements

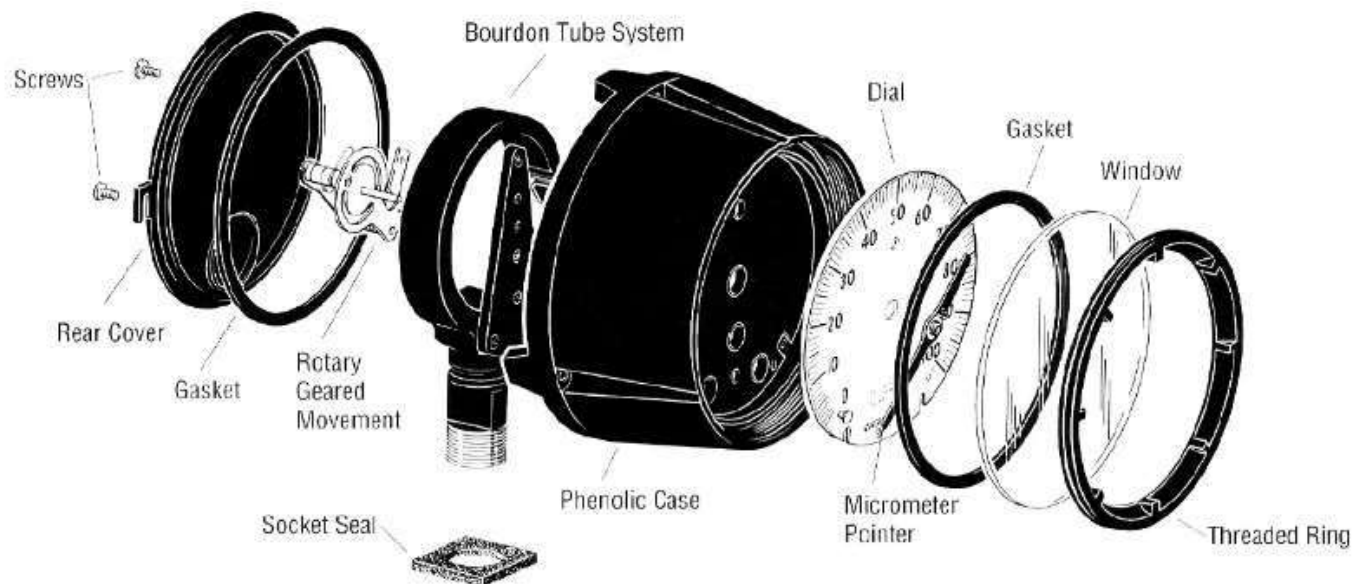
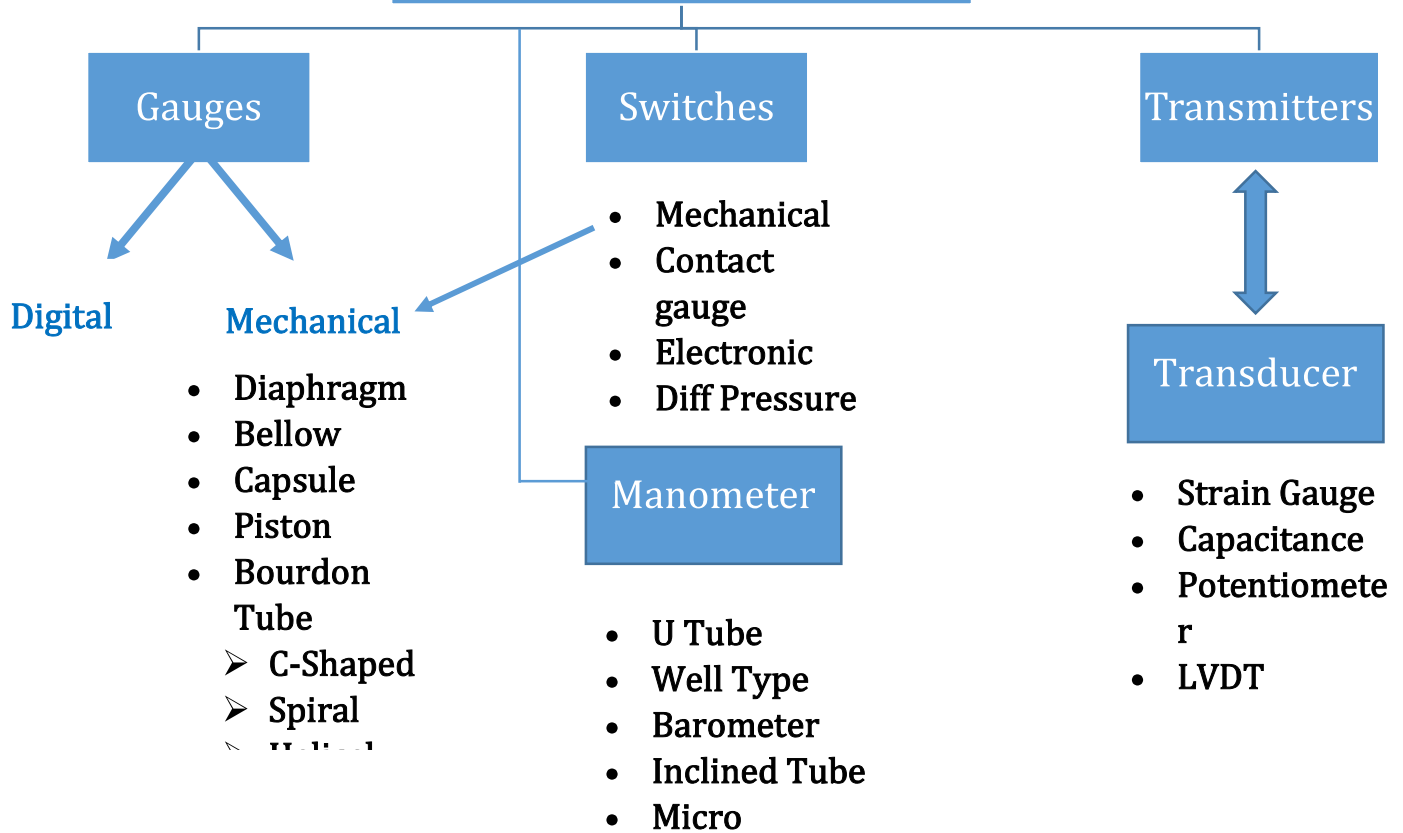

**Typical pressure gauge assembly**

## Pressure Gauge

### ❖ Digital Pressure Gauge:

- With an accuracy up to 0.025% of span, it can be used for calibration.
- They are expensive.



### ❖ Mechanical (Analog) Pressure Gauge:

Based on pressure sensing(primary) element.



#### ➤ Bourdon Tube:

- Used for medium & high pressures.
- Range: (0.6: 7000) Bar.

<b>Advantages</b>	<b>Disadvantages</b>
Accurate results at high pressure	Not suitable with low pressure
Low cost	Not suitable with overload protection
Simple construction	Not suitable with critical media
Safe even for high pressure	

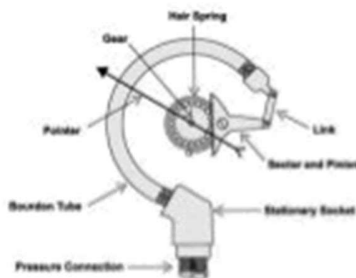

"C" Type Bourdon



Helical Bourdon

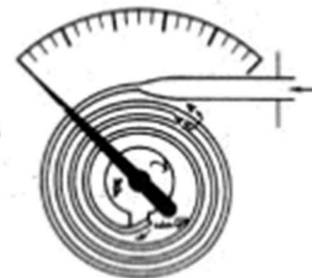

Coiled Bourdon

### ✚ Pressure Gauges Brands :

- WIKA
- ASHCROFT
- WISE
- WINTERS



✓ **C-Shaped Bourdon Tube:**

- Cover the majority of applications.
- Pressure is measured by Bourdon Tube converted motion that transmitted directly to the pointer.
- Can be used for positive, negative pressure.
- Range: [ (0:1) Bar – (0:1360) Bar].

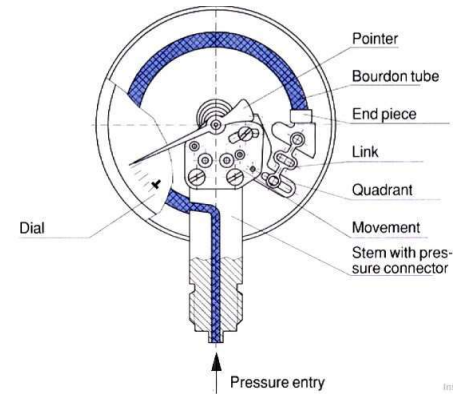

✓ **Spiral Bourdon Tube:**

- Can be used for positive, negative pressure.
- More sensitive & accurate.
- Used for Low pressure range (< 0.7 Bar).

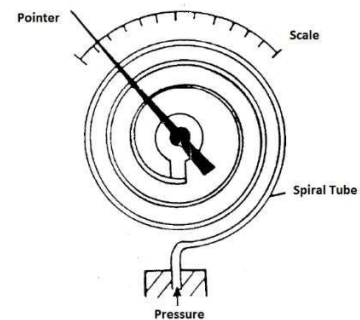

✓ **Helical Bourdon Tube:**

- Helical is a bourdon tube wound in the form of helix. It allows the tip movement to be converted to a circular motion.
- By installing a central shaft inside the helix along its axis and connecting it to the tip, the tip movement become a circular motion of the shaft.
- Higher over range protection.
- More sensitive & accurate.
- Range: [ (0:2) Bar – (0:5000) Bar].
- Very expensive.

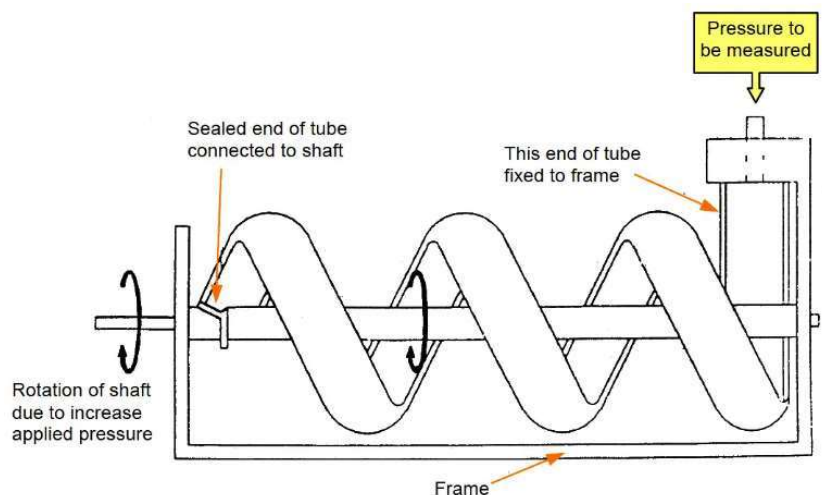

➤ **Diaphragm Pressure Gauge:**

- The pressure is transmitted wave shape diaphragm to a link this then transfer the pressure to the movement of pointer.
- More accurate .
- Insensitive to vibration.
- Low pressure range:( 0:16 mBar & (0:40 Bar).
- Overload protection (5X,10X).
- Critical media (Chemicals&Viscous).

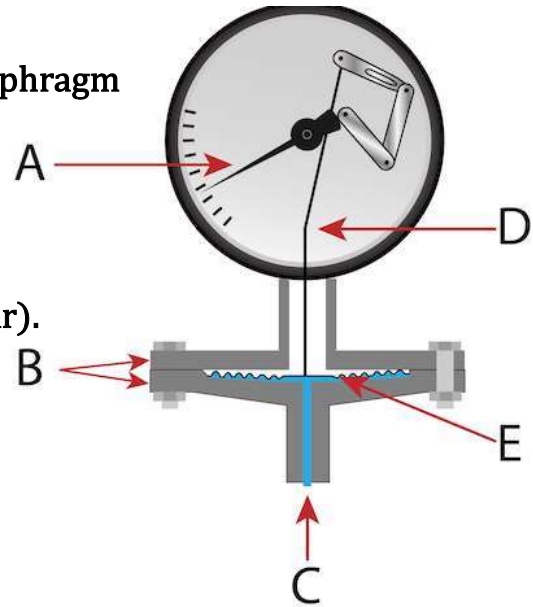
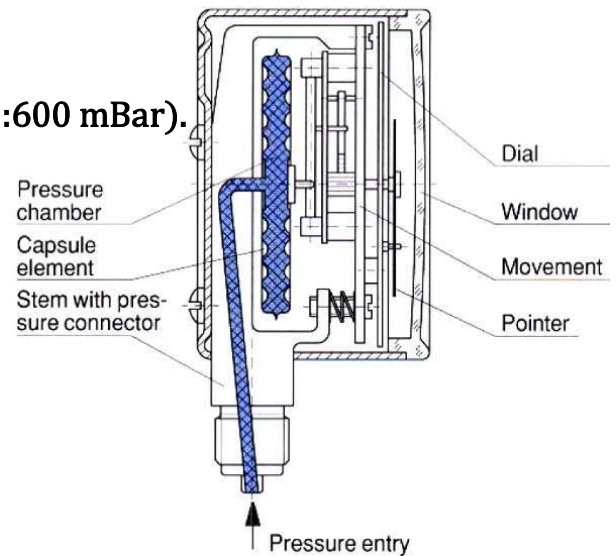

Figure 2: Operating principle of a diaphragm pressure gauge: pointer (A), upper and lower housing (B), pressure inlet (C), pressure element (D), and diaphragm (E).

➤ **Capsule Pressure Gauge:**

- Diaphragm is a single sheet , joining Two diaphragm to form a capsule.
- Very Low pressure range:( 0:2.5 mBar & (0:600 mBar).
- High accuracy ( 0.1 % : 2.5 % ).



✚ **Pressure Gauges failure & safety risk :**

- Temperature
- Corrosion
- Vibration
- Overpressure

## **How to select Pressure Gauges :**

1. Accuracy ( $\pm 1\%$ ).
2. Dial size ( 1.5 " : 10 " ).
3. Mounting ( Bottom - Back ) Connection.
4. Environment ( Water - Chemical - Vibration - Oil - Gas ).
5. Process connection size ( 0.25 " NPT - 0.5 " NPT ) . #National Pipe Thread
6. Pressure range [ max range in between(25%:75%)].
7. Accessories ( fill media-Siphons-Diaphragm seals).



## **How to calibrate Pressure Gauges :**

1. Gauge comparator ( Pump).
2. Reference gauge ( Digital ).
3. Gauge under calibration.

### ➤ Basic procedure of pressure gauge calibration:

- Connect the equipment's as shown .
- Apply pressure 0%(zero adjust).
- Adjust the zero screw or put the pointer on 0%.
- Apply pressure 100%(span adjustment).
- To correct the indication increase or decrease the sector arm.



- Apply pressure 50%(linear adjust).
- Adjust the length of link or pull the pointer using puller and place at correct spot.
- Check points 0%,25%,50%,70% and 100%.
- Repeat these steps to get correct values.



### Pressure Transmitter

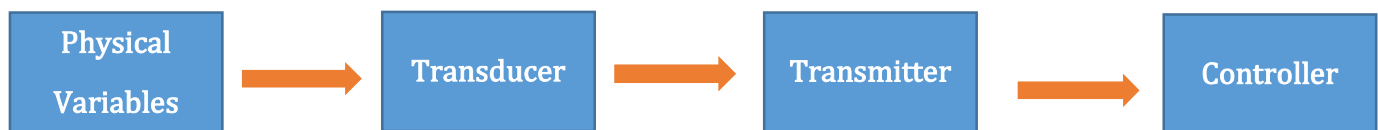
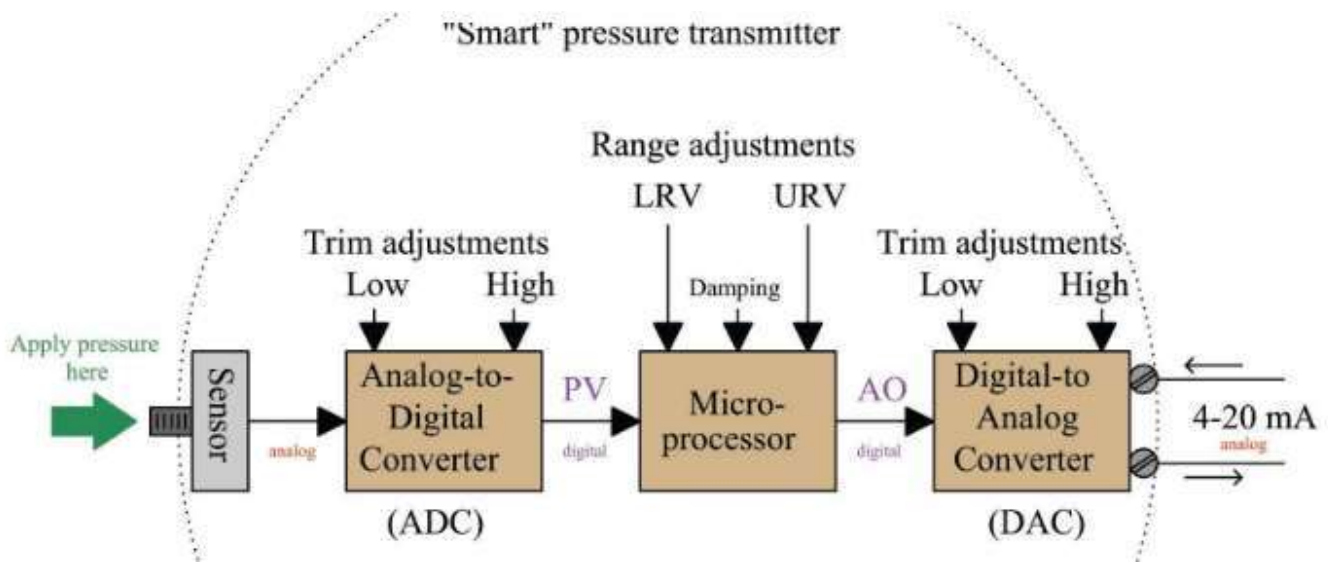

## What's inside of a pressure transmitter?

- Pressure Port
- Sensor (Transducer)
- Signal conditioning electronics module
- Electrical connection

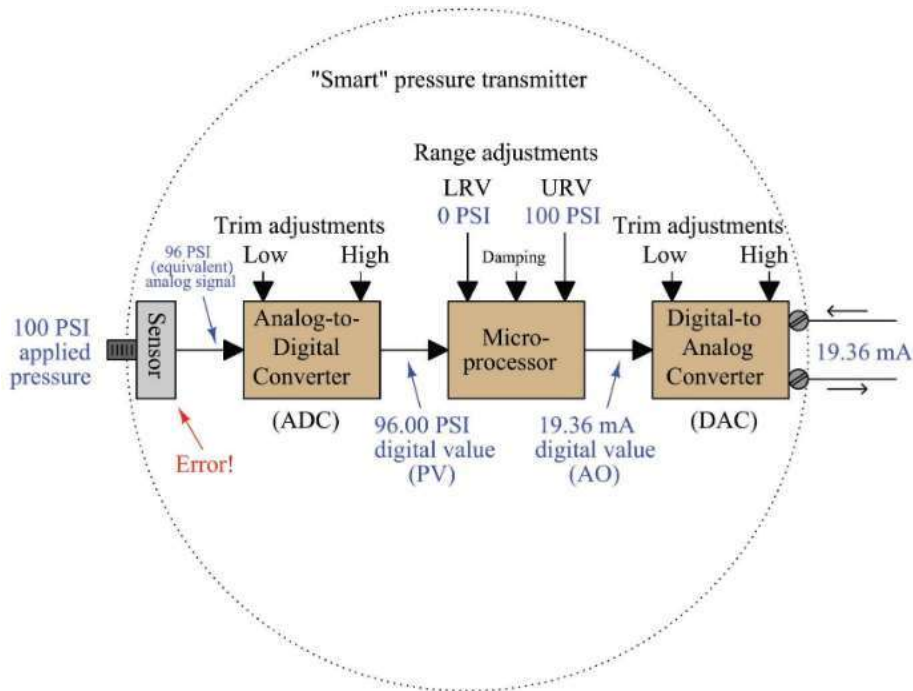
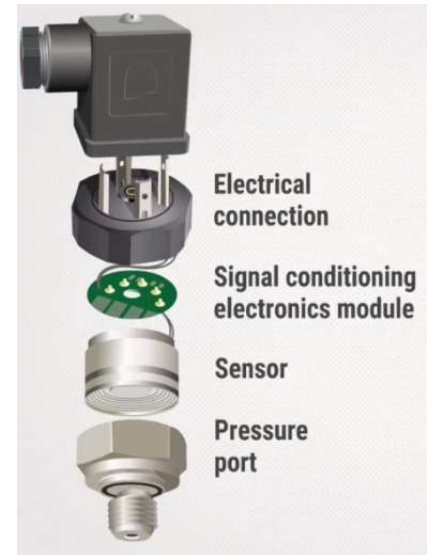

- 1) Strain Gauge
- 2) Capacitance
- 3) Potentiometer
- 4) LVDT

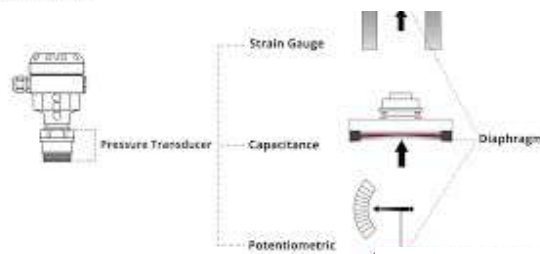

## ➤ Transducer:

### 1) Strain gauge:

The strain gauge is a classic example of a piezoresistive element, Piezoresistive means “pressure-sensitive resistance,” or a resistance that changes value with applied pressure.

### 2) Capacitance:

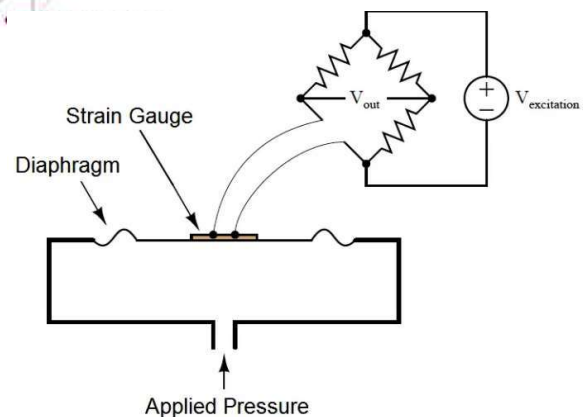

Capacitive-type transducers, illustrated in Figure, consist of two flexible conductive plates and a dielectric. In this case, the dielectric is the fluid. As pressure increases, the flexible conductive plates will move farther apart, changing the capacitance of the transducer. This change in capacitance is measurable and is proportional to the change in pressure.

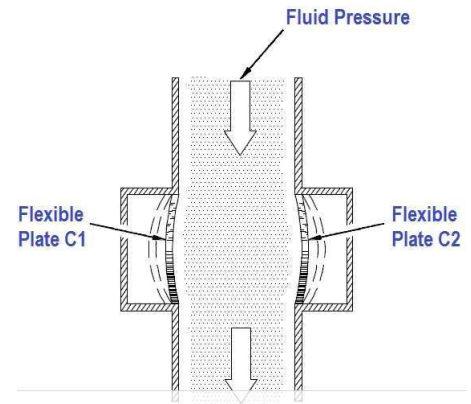

### 3) Potentiometer:

A potentiometric pressure transducer is composed of three major parts:

- Capsule
- sliding contact wiper
- resistance wire winding.

The capsule is connected to the wiper through a linkage rod. When pressure is applied to the capsule, it changes the position of the wiper across the potentiometer. As a result, there is also a change in resistance between the wiper and the potentiometer. Therefore, the mechanical deflection is converted into a resistance measurement.

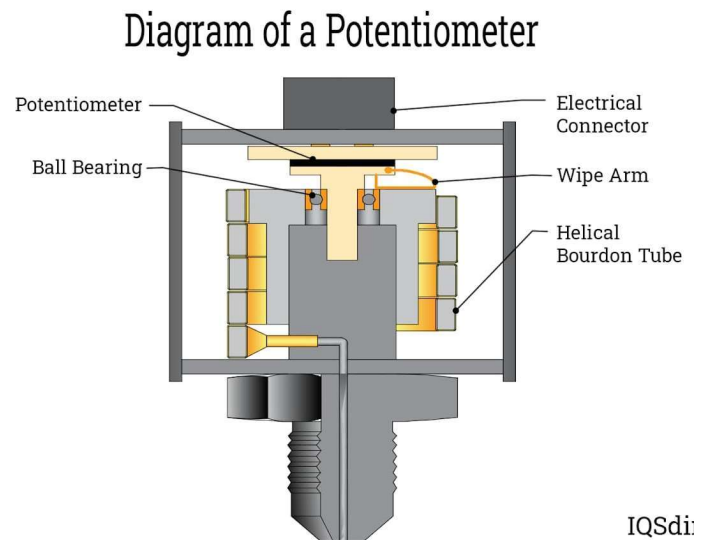

IQSdi

### 4) Linear Variable Displacement Transducer (LVDT):

LVDT works under the principle of mutual induction, and the displacement which is a non-electrical energy is converted into an electrical energy.

And the way how the energy is getting converted is described in working of LVDT in a detailed manner.

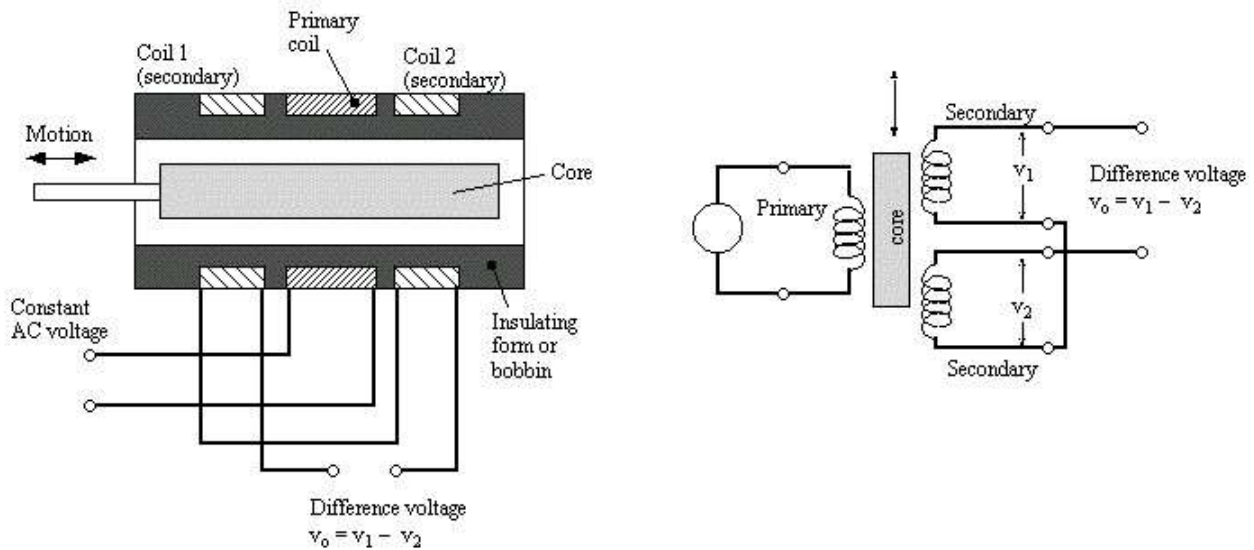

It converts linear displacement into an electrical signal. It comprises one primary and two secondary coil windings. Both windings are an equal number of turns and they are connected in series to each other. The primary winding is placed as opposed to the two secondary windings as shown in the below figure.

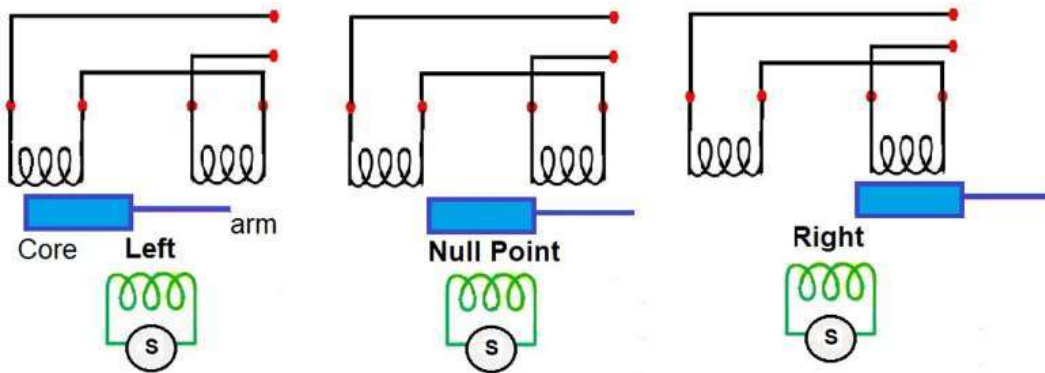

The primary winding is excited by the alternating current; the core is placed inside of it. The alternating current induces flux in primary and by mutual induction, the flux is induced in secondary.

➤ Signal conditioning electronics module:

It converts sensor signal into standard normalized electric output such as :

- 4:20 mA
- 0:20 mA
- 0:5 V
- 0:10 V

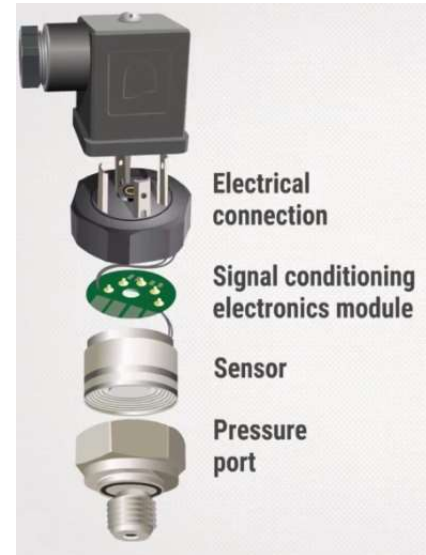

➤ Electrical Connection:

It's used to wire a pressure transmitter to a measuring system.

✚ Why 4:20 mA is the best ?

- (0:10 V) : Current signals can extend much further than voltage signals, allowing robust signal wire lengths of up to 1,000 meters ( **Voltage drop**).
- (0:20 mA ) : In this case, it would be extremely difficult to identify that either 0mA current is due to open circuit of the transmitter or it is due to no pressure of the fluid. (**Live Zero**)
- Current signals are less susceptible to **noise** than voltage signals. Therefore, the 4-20mA output is inherently noise-resistant.( and it's possible to use unshielded cable when installing them)
- The **electronic chips** required to function proper **3 mA** as the minimum current .
- Dangerous current threshold for the **heart** is over **30 mA**.
- Induced **eddy current** (result fault at reading ) has affect at less than 4 mA.
- Easy conversion from 4:20 mA to **1:5 VDC** using **250 ohm** .
- For easy calculation (**20% bias** ) 4-20 mA (analog devices)like 3-15 PSI (pneumatic devices).

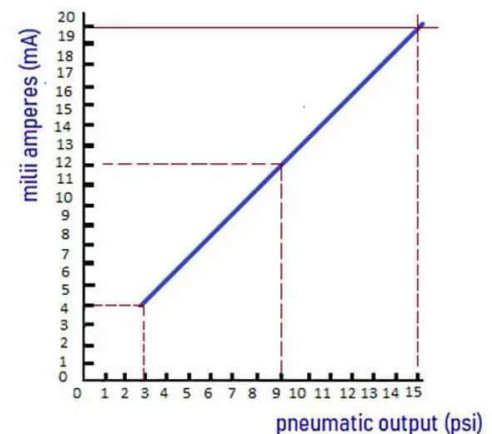

## Why I need to convert 4:20 mA to 1:5 VDC ?

- Pressure transmitter send 4:20 mA to Analog input module.
- AI module need to convert analog signal to equivalent binary signal (010101) that PLC or DCS processor can deal with.
- AI module consist of A/D converter (ADC).
- A/D converter need voltage as input signal to convert them to equivalent binary signal (0,1) so we had to convert 4:20 mA to 1:5 VDC using 250 ohm as a standard resistance.

## What is an P/I converter?

- We can construct a pressure to current converter using a Flapper- Nozzle arrangement , Bellows and a Linear Variable Differential Transformer (LVDT) circuit.
- Input pressure is given to Flapper-Nozzle arrangement and the output current will come through the LVDT.

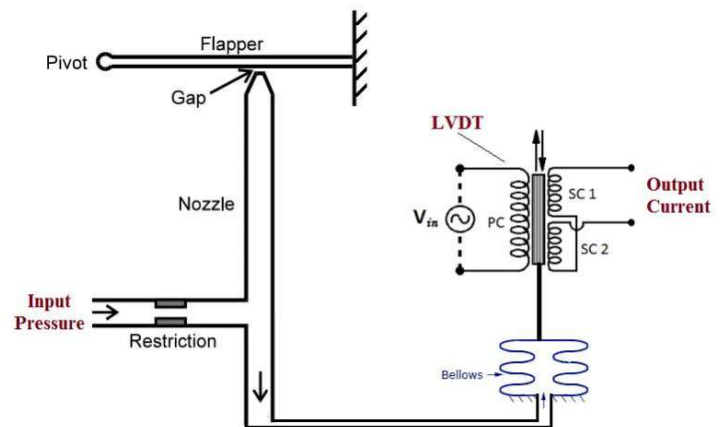

## What is an I/P converter? Working Principle, Applications

- I/P converter is a current to pressure transducer that works on the flapper nozzle method. I/P converter translates the input 4 to 20mA current signal into equivalent output of 3 to 15 PSI pressure.

### Working principle

- Pneumatically operated control valves require a converter or transducer to change the proportional electrical signal to a proportional pneumatic signal. Generally, the converter comes as part of the valve.
- Its purpose is to convert the analog signal output

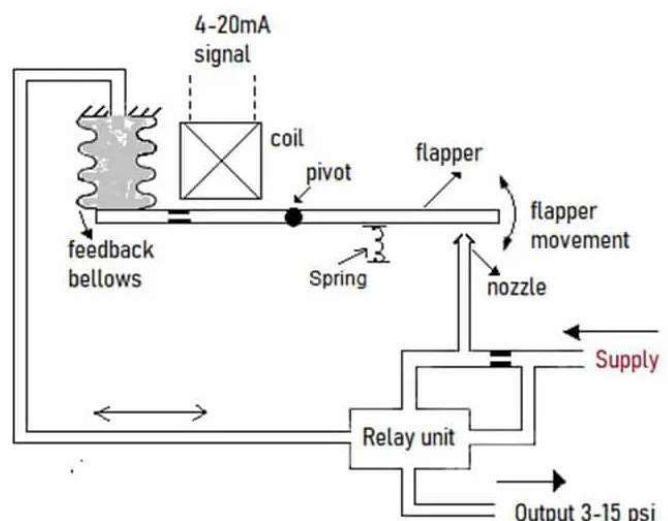

of a control system into an accurate repeatable value of pressure to control pneumatic actuators/operators, pneumatic valves, dampers, vanes, etc.

- The controller output sends an electronic signal to the current-to-pressure (I/P) transducer, which in turn sends a pneumatic signal to the control valve. The control valve changes position in response to the signal to adjust the flow rate to the set point. As the flow changes. It is detected by the flow transmitter.

As long as the detected flow is equal to the set value, the valve position will remain the same. Whenever there is a system disturbance or set-point change, the flow control automatically responds to reach the programmed set point.

## Application of I/P converter

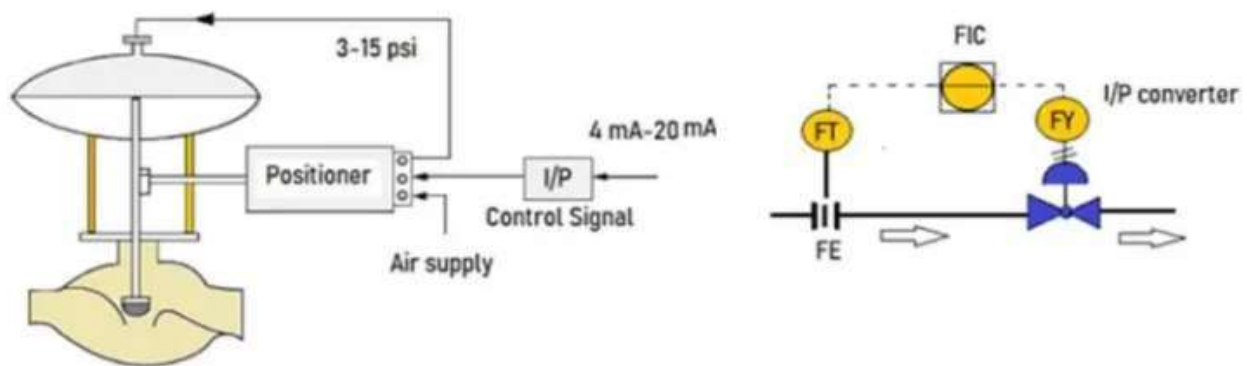

## **✚ How to select pressure transmitter?**

1. Type of pressure measured [ Gauge – Absolute – Differential].
2. Pressure range [actual measurement is as 80% of range].
3. Measured media [ gas – viscous-sea water].  
# sea water : high nickel content alloys { INCONEL alloy718}.
4. System maximum overload.
5. Accuracy level [ 0.05%: 0.5%].
6. Operating temperature range.  
# at high temp you can install condensing , radiator or siphon .
7. Power supply & output signal.
8. Working environment [ vibration – electromagnetic interference].  
#IP : Ingress Protection {first digit : Solid & 2<sup>nd</sup> digit : Liquid}
9. Pressure interface connection [M20x1.5].

## **✚ Transmitters mounting rules?**

- Prevent moisture to reach transmitter cable connection.

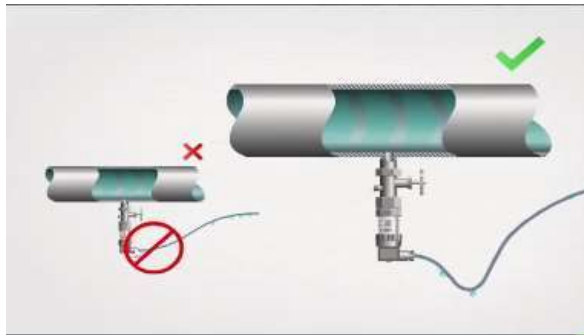

- Used shielded cables if theirs is close power equipment.
- Cable shield must be completely undamaged.
- Avoid to mount the transmitters cable upwards.

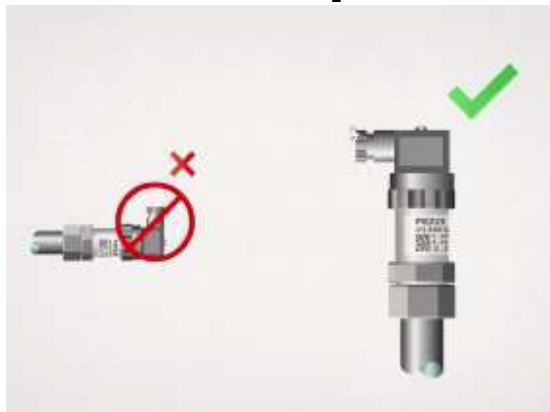

## **How to calibrate Pressure Transmitters :**

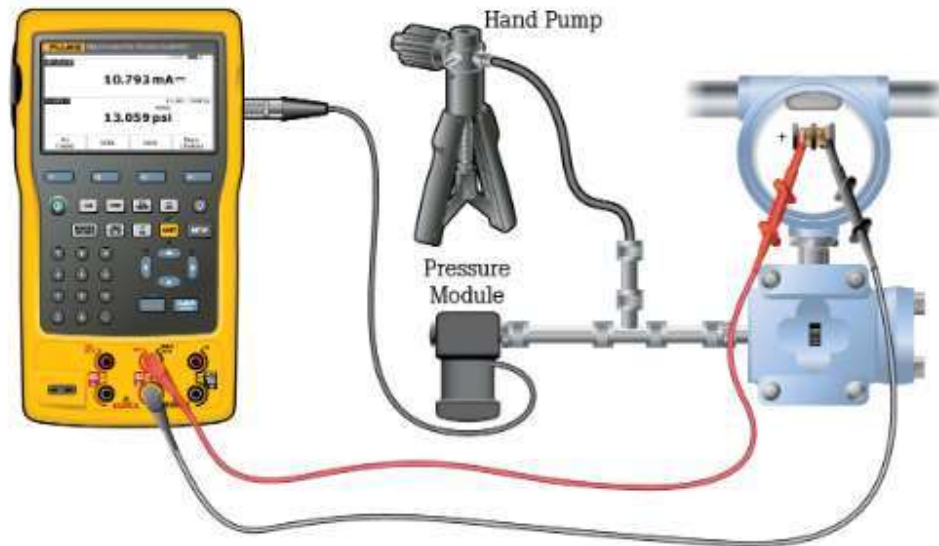

- ✓ First isolate the main process isolation valve.
- ✓ De-pressurize the pressure transmitter by opening the vent valve
- ✓ Isolate the manifold valve and open the vent plug.
- ✓ Fix proper instrument fitting ( for eg:1/4"npt fitting)
- ✓ Connect the calibrator fitting in to the vent plug entry of manifold valve.
- ✓ The vent valve should be opened.
- ✓ The HART communicator cable should be placed as per transmitter wiring diagram.
- ✓ Apply pressure as per the range given in the transmitter or check with the HART communicator.
- ✓ Check the transmitter reading by applying pressure for 25%, 50%, 75%, and span range.
- ✓ If the transmitter needs to be calibrated use the HART communicator for calibration purpose.
- ✓ Zero & span trims can be done by using HART communicator.
- ✓ After calibration checking remove the pressure calibrator from the transmitter and flush the line.
- ✓ So that hydraulic oil or water will not be inside the transmitter.
- ✓ Close the vent plug.
- ✓ Isolate the vent valve and open the main isolation valve.
- ✓ Open the manifold isolation valve slowly, if u open fast sudden pressure may damage the transmitter diaphragm.
- ✓ After completion of the calibration ensure the transmitter is reading showing properly.
- ✓ Then enter the reading in calibration report format.

## How to connect HART communication?

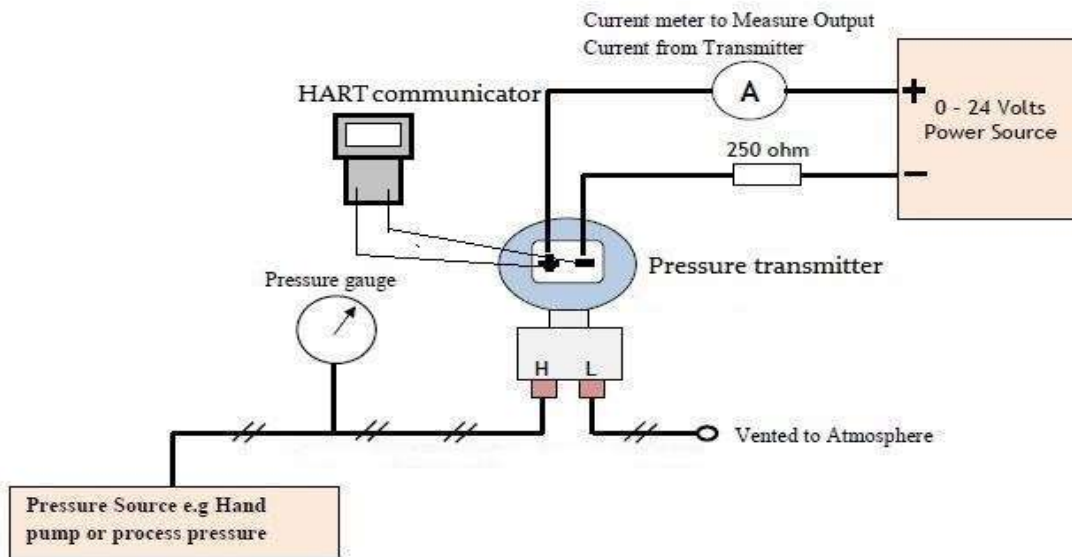

**Highway  
Addressable  
Remote  
Transducer  
Protocol**

Figure 1-3 and Figure 1-4 illustrate typical wiring connections between the HART Communicator and any compatible device.

HART-compatible  
Device

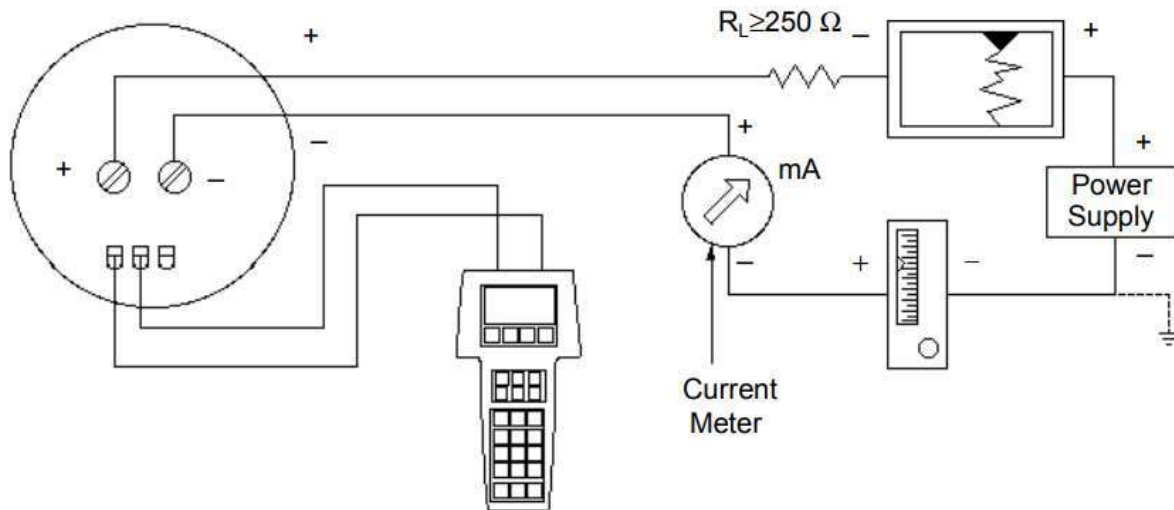

FIGURE 1-3. Connecting to the Transmitter Comm Terminals.

### Resistance value:

The HART specification defines the loop resistor value to be in the range of 230 ohms to 600 ohms. Typically, 250 ohms is used. This value provides an easy conversion from a current value to a voltage value used in some control systems. In this case 4mA through a 250 ohm resistor is 1Vdc and 20mA is 5 Vdc.

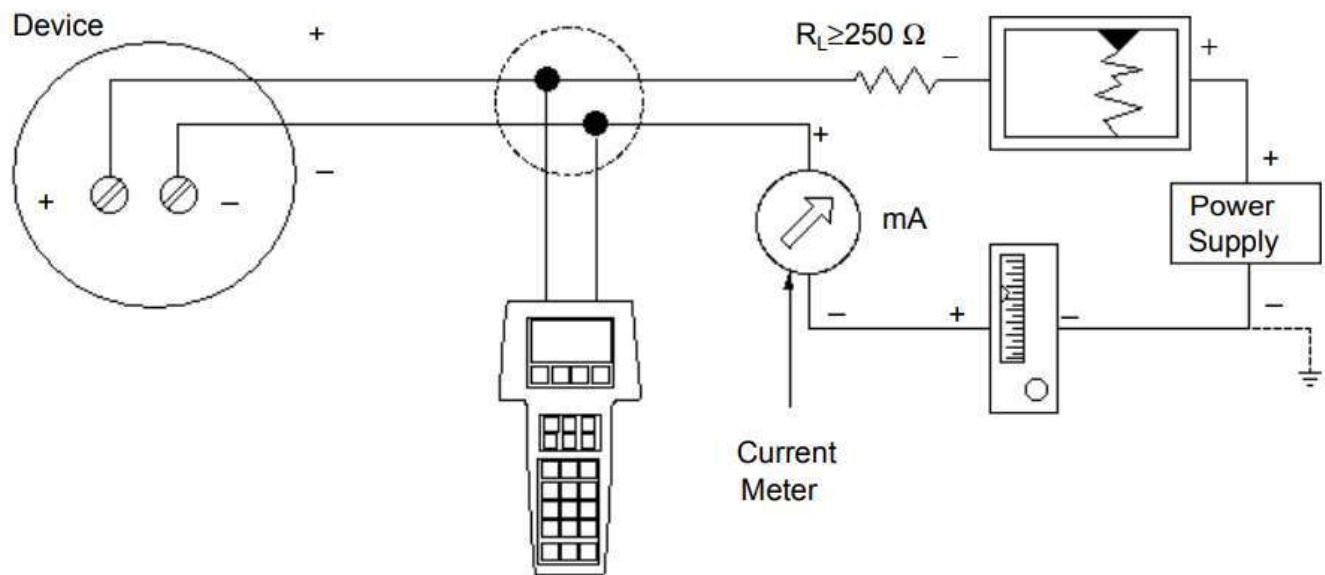

FIGURE 1-4. Connecting the HART Communicator to the Loop.

Figure 1-5 shows how to connect the optional 250 ohm load resistor.

**NOTE:** To temporarily install the optional 250 ohm Load Resistor:

1. Insert the load resistor into the lead set jacks.
2. Open the loop to allow connection of the resistor in series in the loop.
3. Close the loop using the lead set connectors.

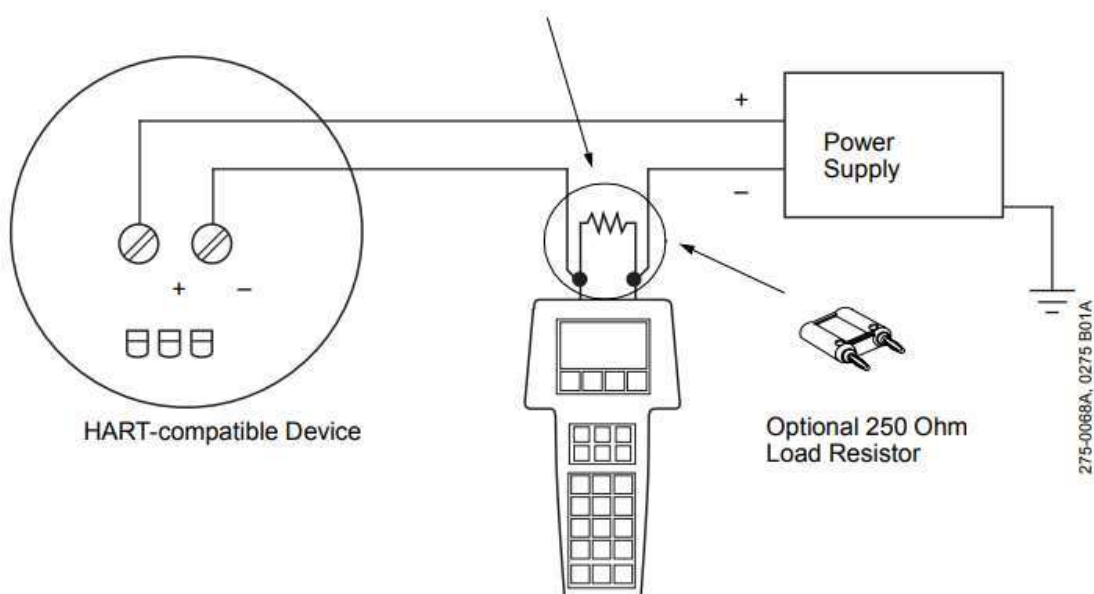

FIGURE 1-5. Connecting the HART Communicator with the Load Resistor.

## Pressure Switch

### ➤ Mechanical Pressure Switch:

- Measure or maintain Pressure , Level of liquid or gas.
- It has spring to return switch.
- Can be used in exponential area.
- Micro switch is used.
- High level electrical power process[250 V-20 A].
- Digital Signal.



### Bourdon Tube Pressure Switch

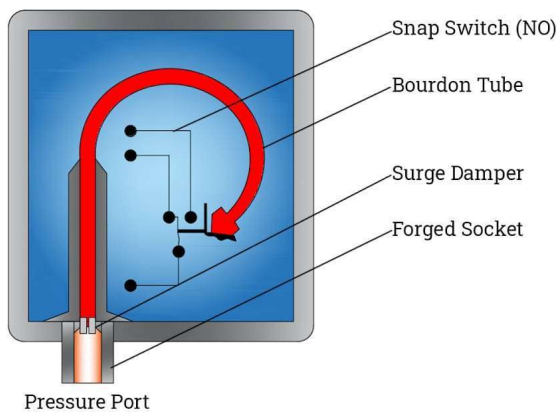

### Diaphragm Pressure Switch

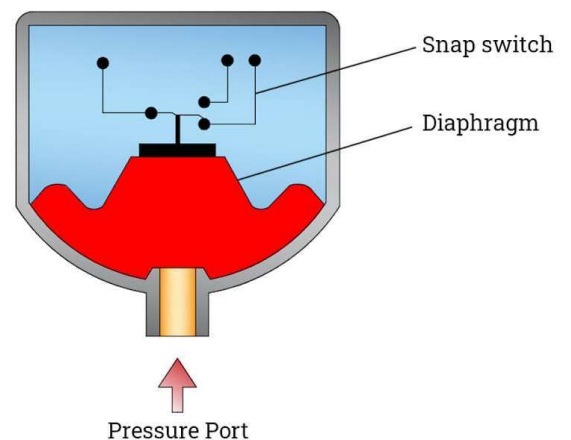

## Piston Pressure Switches

### With Diaphragm Sealing

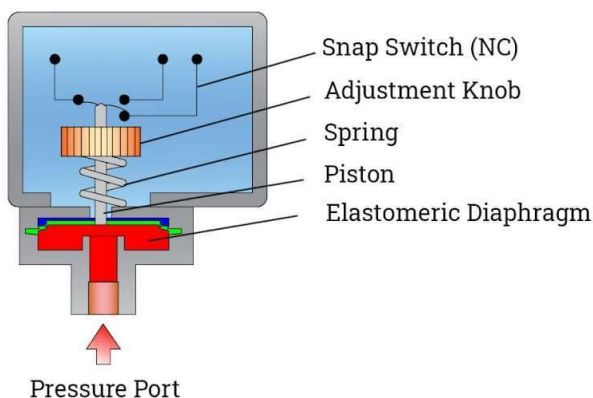

### Without Diaphragm Sealing

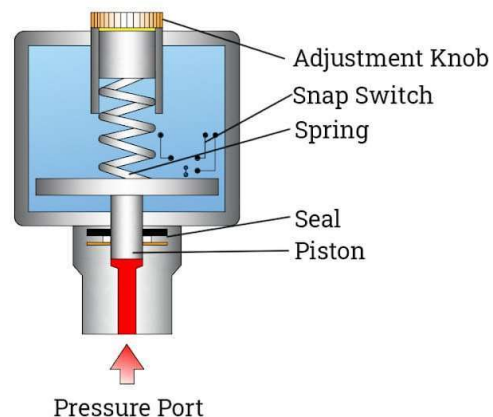

# System start at 3 bar , Stop at 2 bar ( Diff=1).

# you can rotate the RANGE/DIFF screw to adjust RANGE/DIFF setting.

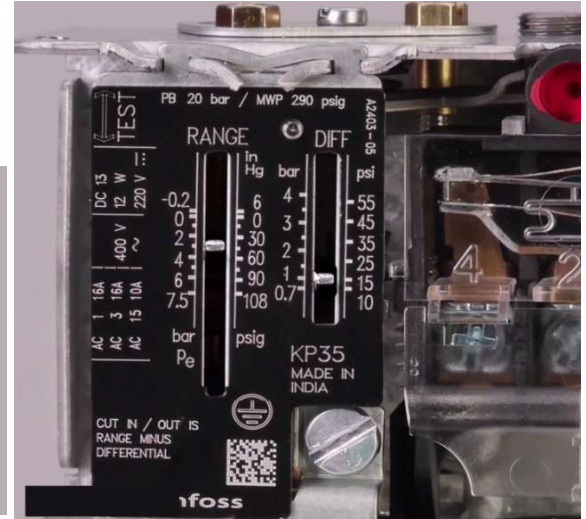
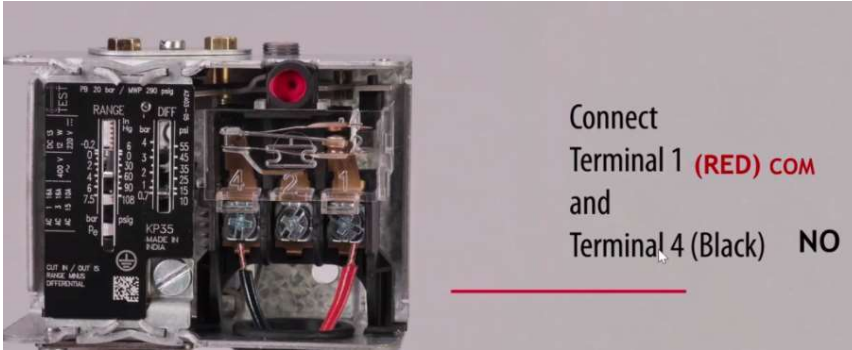

➤ Contact Pressure Gauge:

- Gauges with switch contacts.
- Can be read on site.
- The switch limits can easily be set.
- Used in indication, Protection & control.



Types :

First Choice

Almost all operating conditions

Magnetic snap-action contact

Inductive contact

Electronic contact

Reed contact

Switch small voltage

Protected from corrosion

PLC

Hazardous Area Zone 1 & Zone 2

➤ **Electronic Pressure Switch:**

- More accurate & reliable.
- Easy programming of the operation logic.

**Consist of:**

- Pressure sensor element.
- Electronic board.
- Solid state relay.



➤ **Differential Pressure Switch:**

- Filter clogged check by applying differential pressure before and after the filter

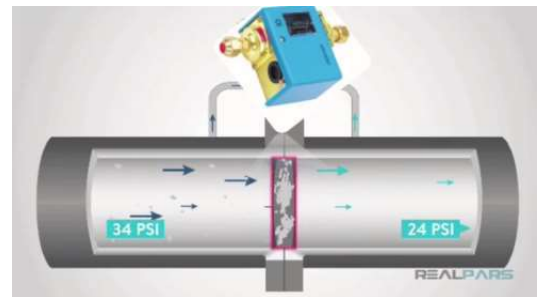

✚ **How to select pressure Switch?**

1. For low pressure ⇒ [ Diaphragm & Bellow].  
For medium pressure ⇒ [ Bourdon & Piston].
2. High service life (operate more than 1 Million) ⇒ [ Piston].  
Less than 1 Million ⇒ [ Diaphragm & Bourdon].
3. Fast cycling ⇒ [ Piston].
4. High accuracy ⇒ [ Diaphragm & Bourdon].
5. Adjustable range . [ the set point should be in middle of 30% : 65%].
6. Types of switch action :
  - Standard pressure
  - Differential pressure
  - Dual switch sense
7. Fluid media.
8. Proof pressure (is the highest pressure that the switch will stand without permanent deformation), usually defined as 1.5 times max working range.

## How to calibrate Pressure Switch?

There are several terms that describe the function of a switch which need to be understood when testing a pressure switch:

Set point: The pressure which the switch will change state.

Normal State: The state of the switch when at barometric pressure or ideal state.

Depends on Pressure switch type.(typically it would be either OPEN or CLOSED).

Reset: The pressure at which the switch resets back to the normal state.

Tolerance: The allowable variation from the set point pressure.

Repeatability: The closeness of agreement between the results of consecutive measurements.

Dead Band: The pressure difference between the change-of-states. (i.e. OPEN to CLOSE or CLOSE to OPEN)

Trip Type: This is the direction to which the change-of state should happen

If the trip type is low, this means the change-of-state happens when the pressure is falling.

If the trip type is high, this means the change-of-state happens when the pressure is rising.

➤ Calibration Procedure :



1. First we connect the pressure gauge and Pressure switch to the hand pump as shown in above figure.
2. Then we need to measure the present status (NO/NC) of electrical output of the switch with the multimeter. Put multimeter in Continuity mode.
3. Note: Here in this example our pressure switch considered is Normally open type. So when you connect the multimeter before calibration we have default Normally Open (NO) signal as output.
4. With our connections complete, we are ready to perform the calibration. We do this by increasing pressure until we detect a change in the switch.
5. Now increase the pressure with the help of hand pump.
6. When we see the switch change state from open to close, we record the result.
7. Next, we decrease the pressure till we see the switch reset (change from close to open) and record the results.
8. Also record the dead band.
9. Lastly, we would repeat this test at least once to determine repeatability. The difference between set point and rest pressures is the dead band. The dead band must be within the range. The deadband & setpoint of pressure switch available on nameplate of pressure switch.
10. For Normally closed Pressure switch calibration also follows the same above mentioned procedure. But the default status of Normally closed type Pressure switch will have N.C. signal as output. When testing with increasing pressure the output state changes from N.C. to N.O and while on decreasing pressure the output state changes from N.O. to N.C. Remaining all steps are same.

## ④ Temperature Measurements

Temperature is one of the most common process variables measured in industries.

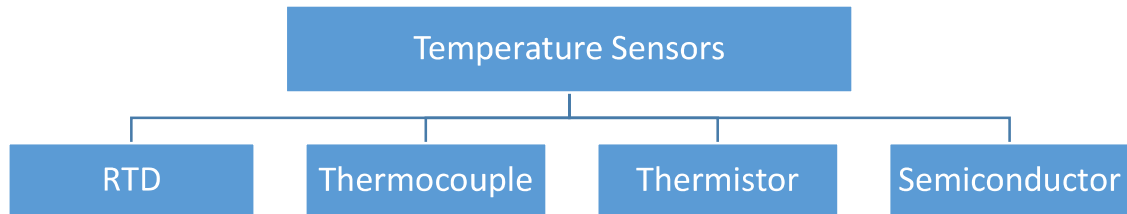

### ➤ RTD (Resistive Temperature Detector):

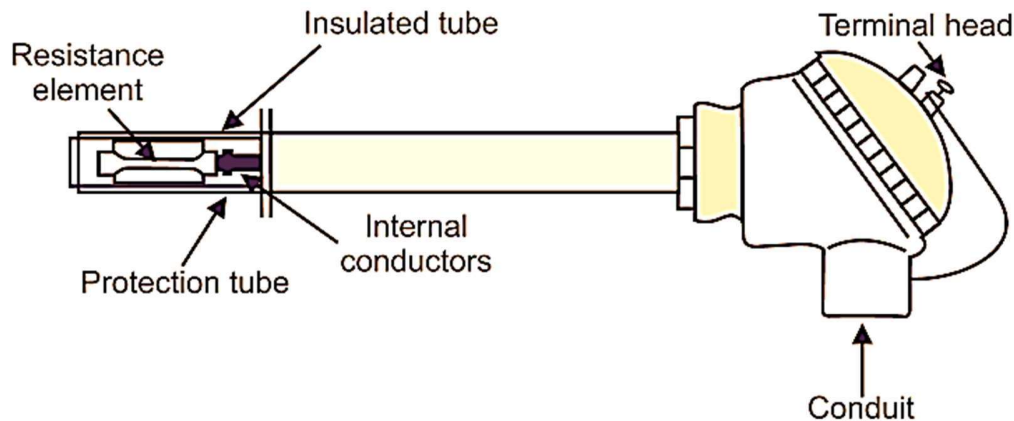

- The RTD wire is a pure material (platinum, nickel, copper) which change their electrical resistance as a function of temperature.
- RTD is a passive device (Need external electrical current).
- Type: [ PT100 , PT300 , PT1000 , .... ].

#### ❖ PT100:

- Mean : 100 ohm at 0 °C
- Type: 2 wire , 3 wires , 4 wires
- $R = R_0(1 + \alpha T)$   
 $R_0 = 100$  ,  $\alpha = 0.0038$   
1 (ohm) = 2.5 °C (above 100 ohm )  
**#110 ohm >>> 10 \* 2.5 = 25 °C**

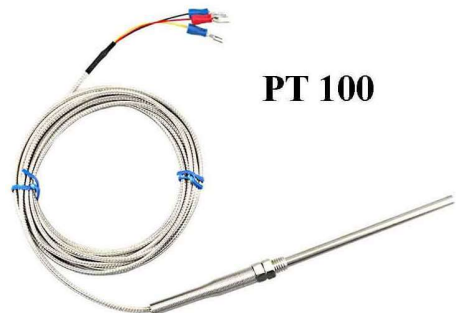

## PT100 in 2-wire connection

With a 2-wire connection, the resistance of the cable is added as an error in the measurement.

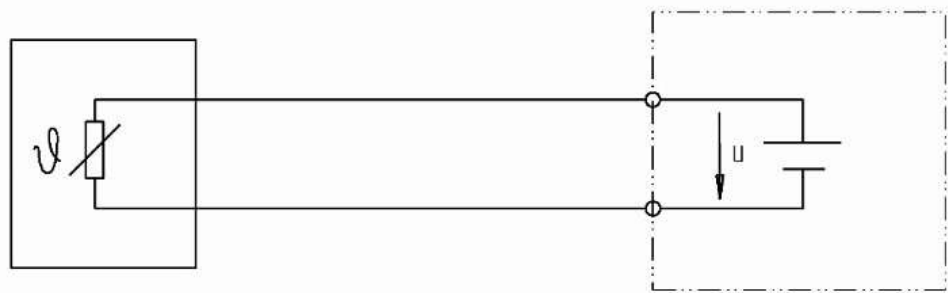

The simple two wire RTD connection shown in Figure is used only where high accuracy is not essential - the resistance of the connecting wires is always included with that of the sensor, leading to errors in the signal (resistance of element + lead resistance, usually copper). In fact, a standard restriction with this installation is a maximum of 1 - 2 ohms resistance per conductor - which is typically about 300 feet of cable. This applies equally to balanced bridge and fixed bridge systems. The values of the lead resistance can only be determined in a separate measurement (without the RTD sensor) and therefore a continuous correction during the temperature measurement is not possible.

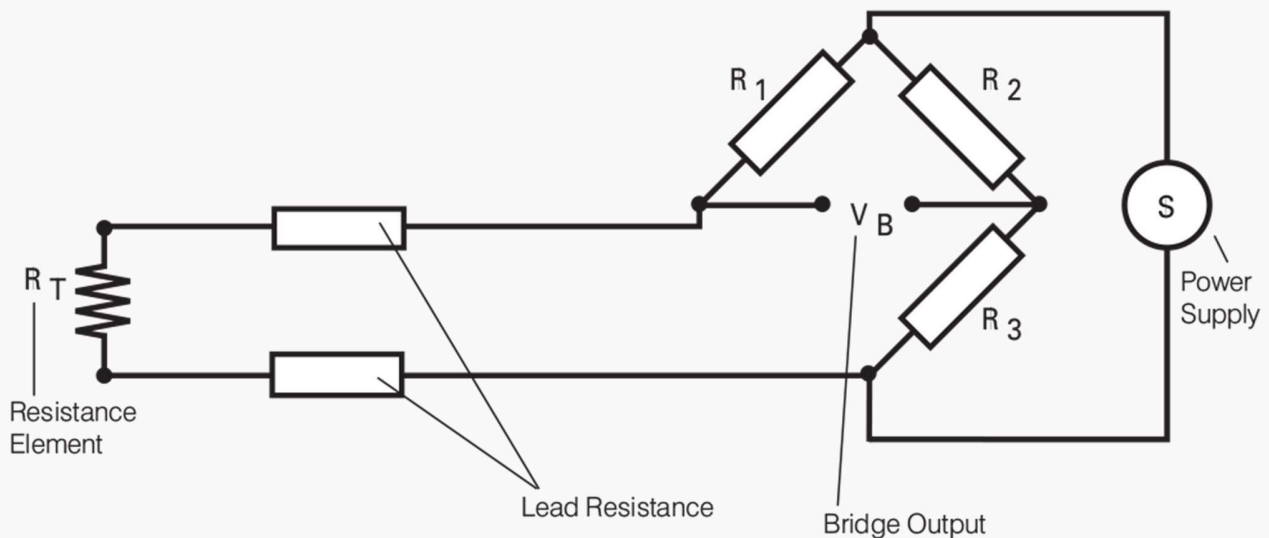

## PT100 in 3-wire connection

The influence of the lead resistance is compensated to the greatest possible extent with a 3-wire connection.

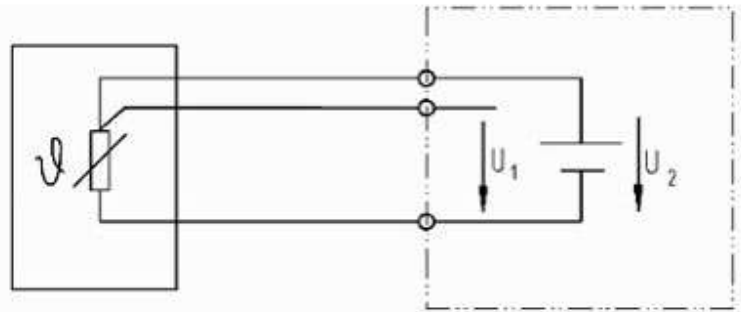

A better wiring configuration is shown in Figure In this RTD circuit diagram, the two leads of the sensor are on adjoining legs. Although there is lead resistance in each leg of the bridge, the lead resistance is cancelled out from the measurement. It is assumed that the two lead resistances are equal, therefore demanding high quality connection cables. This allows an increase to 10 ohms - usually allowing cable runs of around 1500 feet or more, if necessary.

Also, with this wiring configuration, if fixed bridge measurement is being made, compensation is clearly only good at the bridge balance point. Beyond this, errors will grow as the imbalance increases. This, however, can be minimized by using larger values of resistance in the opposite bridge circuits to reduce bridge current changes.

The pt100 3 wire configuration is very popular for general industrial applications and is widely used in terminal heads when used with 4 to 20mA current transmitters and where dual element duplex sensors are used.

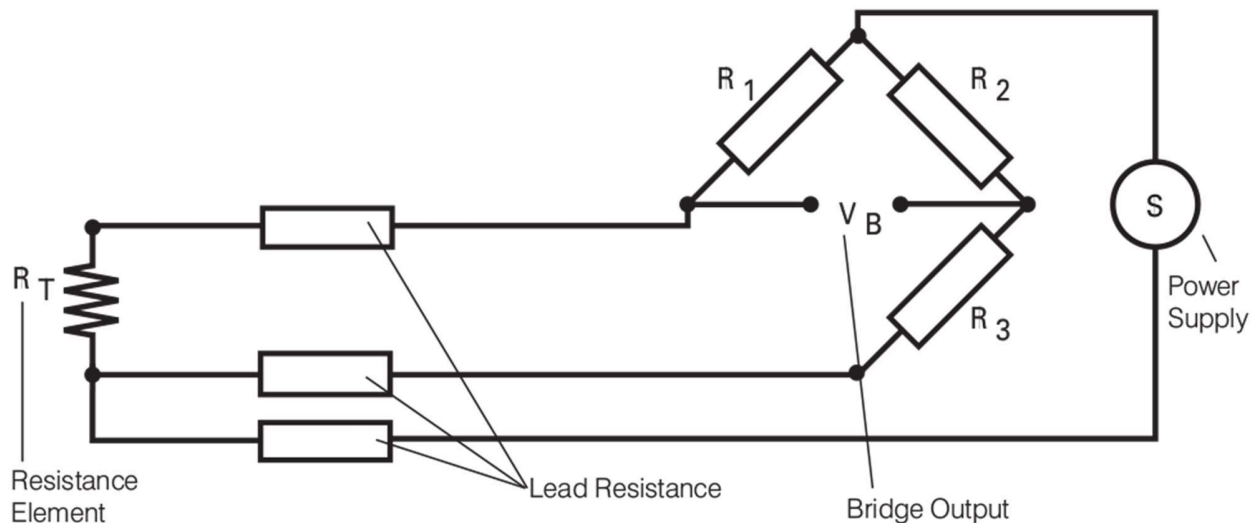

## Pt100 in 4-wire connection

The 4-wire connection completely eliminates the influence of the connection lead on the measuring result since any possible asymmetries in the lead resistance of the connection lead are also compensated.

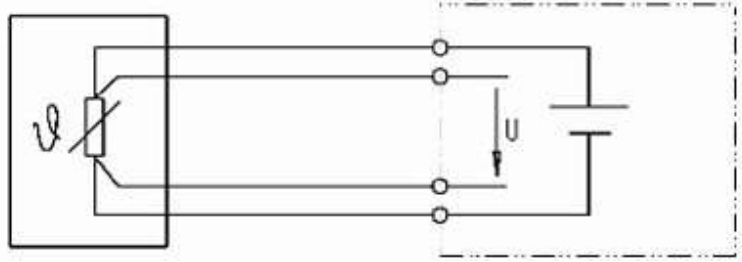

The best wiring arrangement is the four wire configuration as depicted in figure. This provides for full cancellation of spurious effects with the bridge type measuring technique. Cable resistance of up to 15 ohms can be handled with this arrangement, accommodating cable runs of around 3,000 feet. Incidentally, the same limitation as for three wire connections applies if the fixed-bridge, direct-reading approach is being used.

The resistance thermometer can also be energized from a constant current source, and the potential difference developed across it measured directly by some kind of potentiometer. An immediate advantage is that here, incidentals like conductor resistance and selector switch contact resistance are irrelevant. The essentials for this voltage-based method are simply a stabilized and accurately known current supply for the RTD sensor (giving a direct relationship of voltage to resistance and thus to temperature) and a high impedance voltmeter (DVM, or whatever) to measure the voltage developed with negligible current flow.

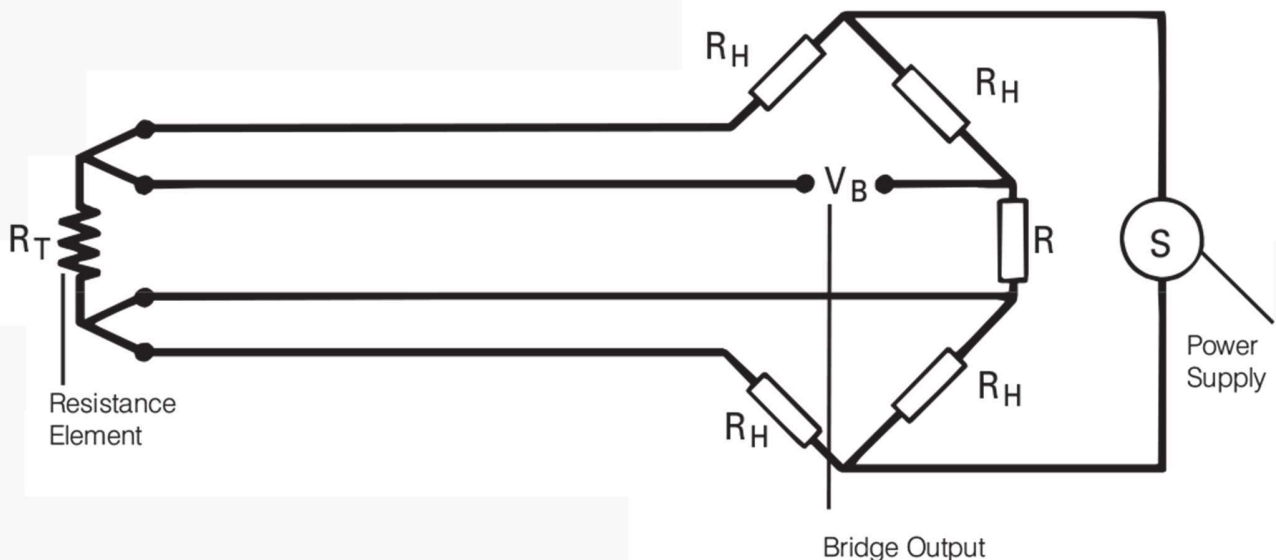

❖ Example: Measuring error at 150 °C, cable length 10 m, conductor cross-section 0.22 mm<sup>2</sup>:

Measuring element	Connection method	Tolerance class	Measuring error in °C
Pt100	2-wire	B	5,25
	2-wire	A	4,65
	4-wire	B	1,05
	4-wire	A	0,45
Pt1000	2-wire	B	1,47
	2-wire	A	0,87
	4-wire	B	1,05
	4-wire	A	0,45

## Conclusion

- The highest measurement accuracies are only achievable with a Pt100 in a 4-wire connection.
- A Pt1000 measuring element in class A also offers good measurement accuracies in a 2-wire connection and represents an economical alternative to 3- or 4-wire connections for machine building.

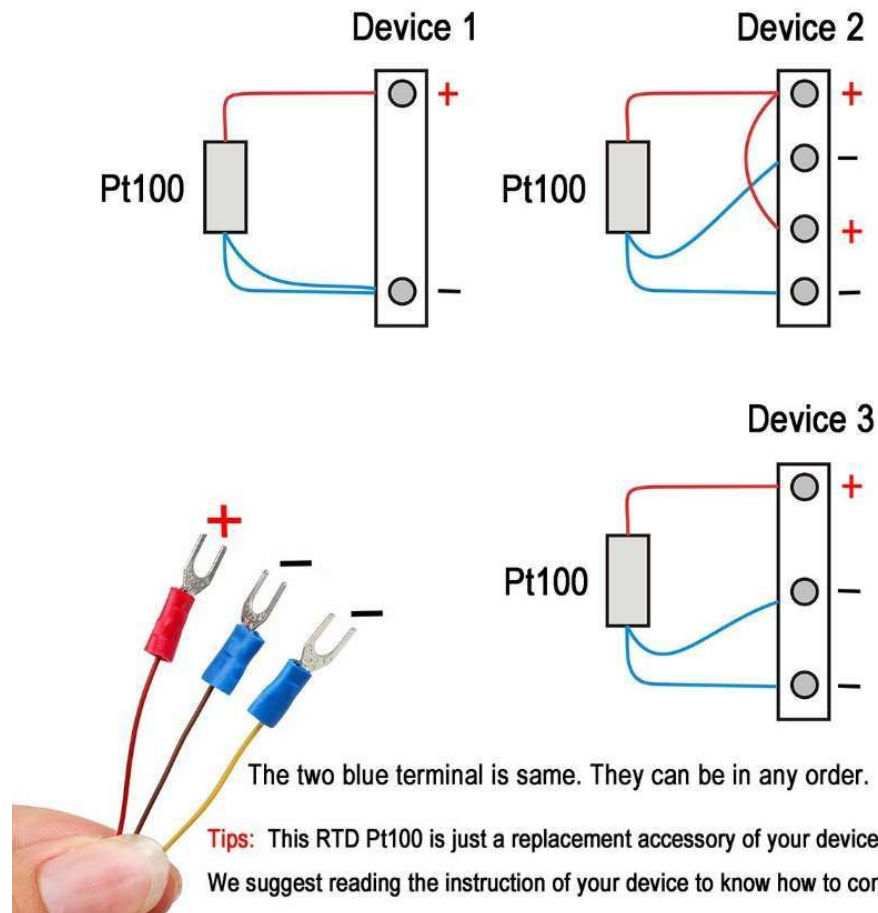

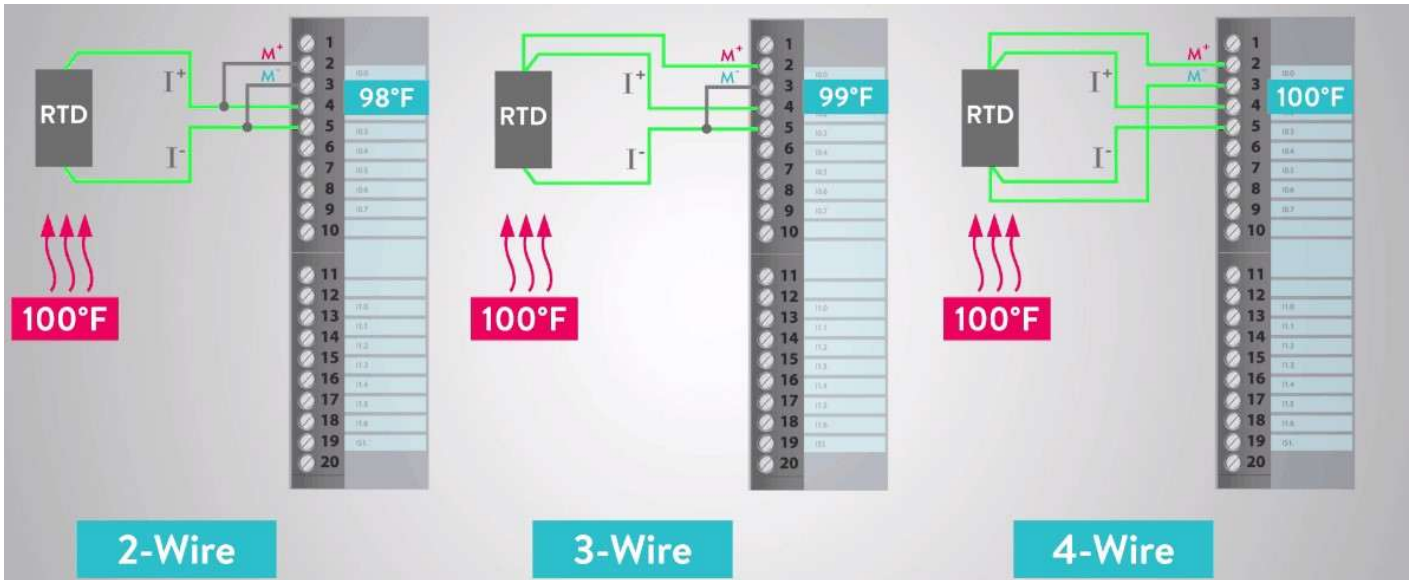

- What happen if we connect PT100(2-wires) far from controller?  
 Error occurs because of cable resistance.
  - ✓ Use 3 – 4 wires .
  - ✓ Use temperature transmitter.
  
- What happen if we connect PT100(3-wires) to 4-wire controller?
  - ✓ make bridge near to sensor **NOT** near the controller.
  
- What happen if we connect PT100(2-wires) to 4-wire temperature transmitter?
  - ✓ make junction as close to the sensor as possible.

➤ RTD Sensor Connections :

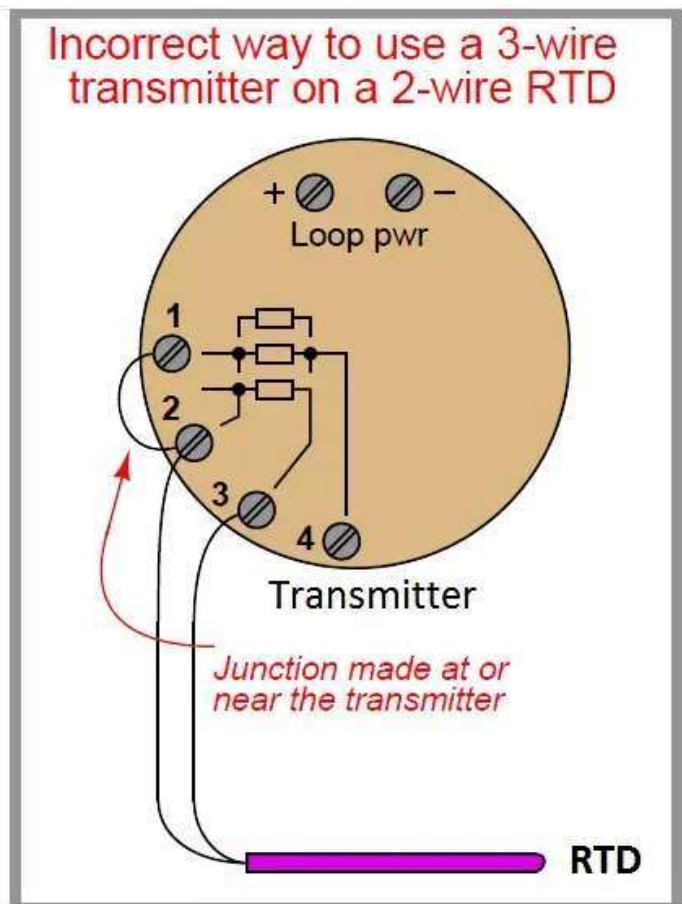
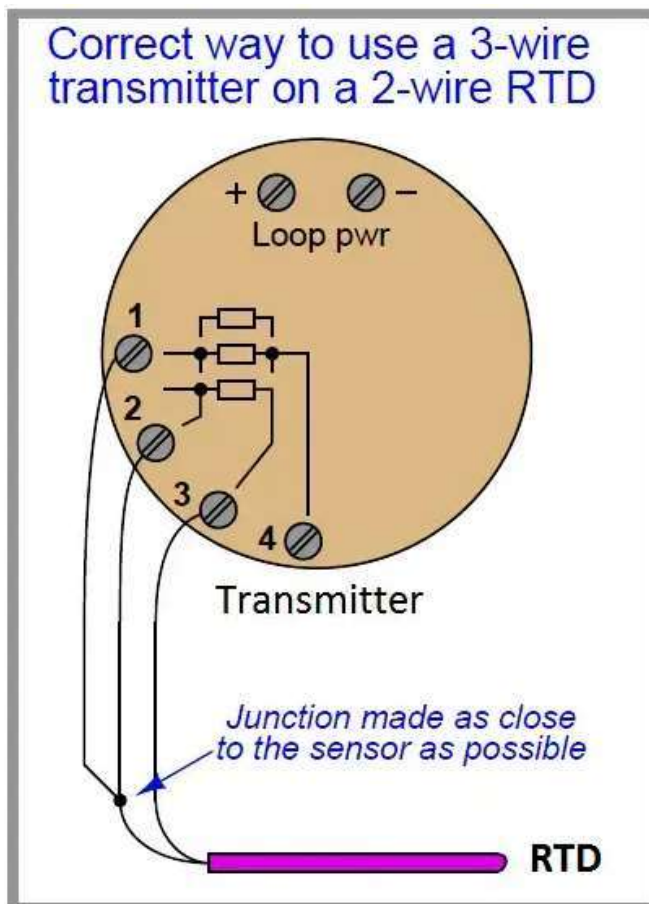
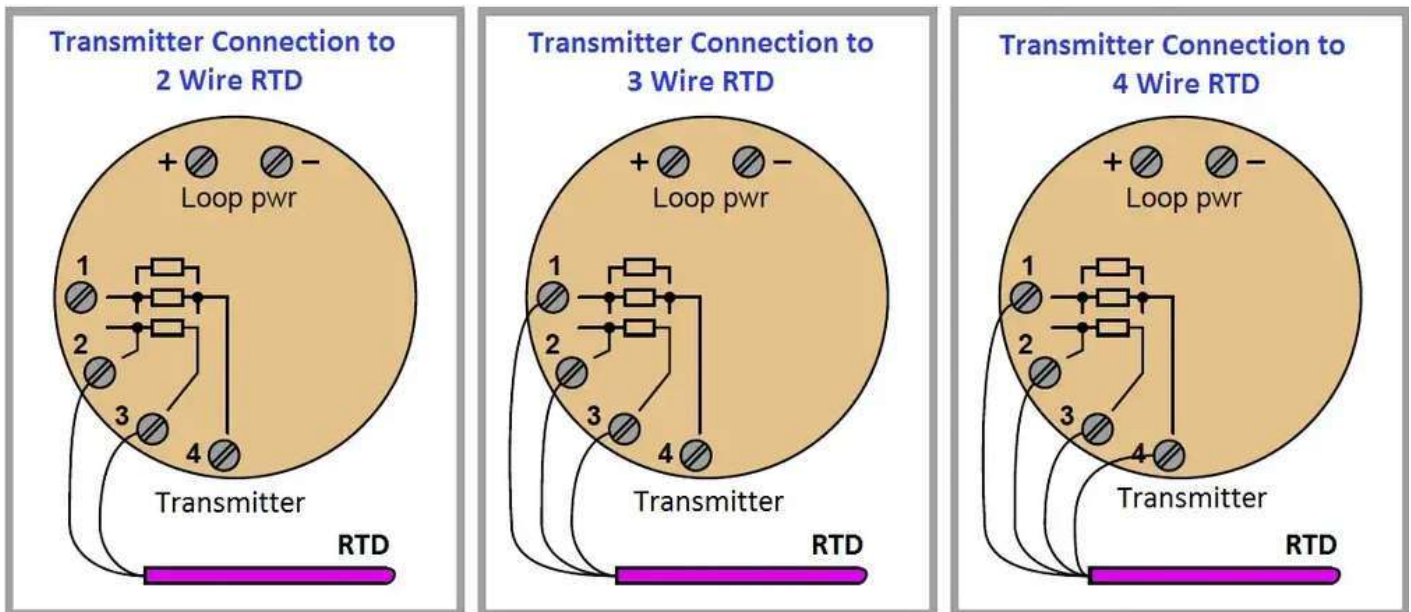

Correct way to use a 4-wire transmitter on a 3-wire RTD

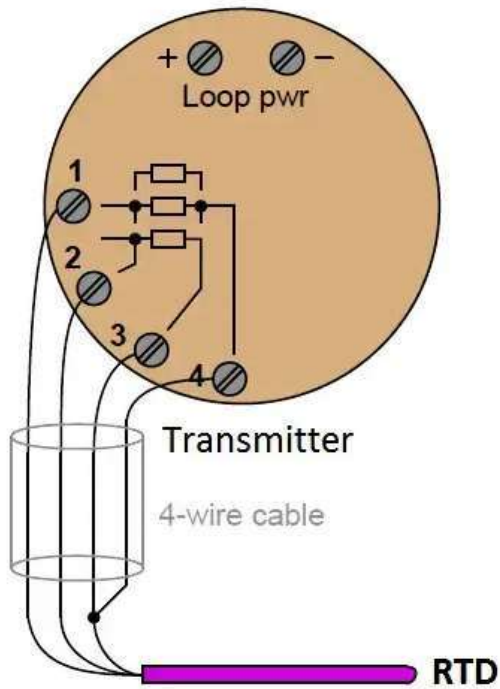

Correct way to use a 3-wire transmitter on a 3-wire RTD

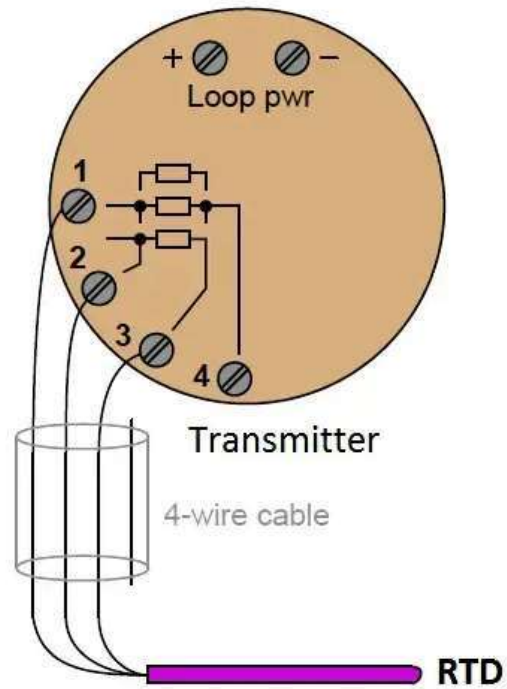

Correct way to use a 4-wire transmitter on a 2-wire RTD

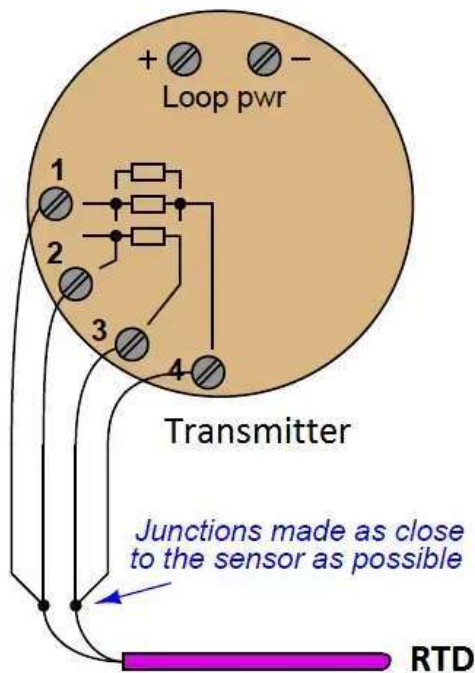

Incorrect way to use a 4-wire transmitter on a 2-wire RTD

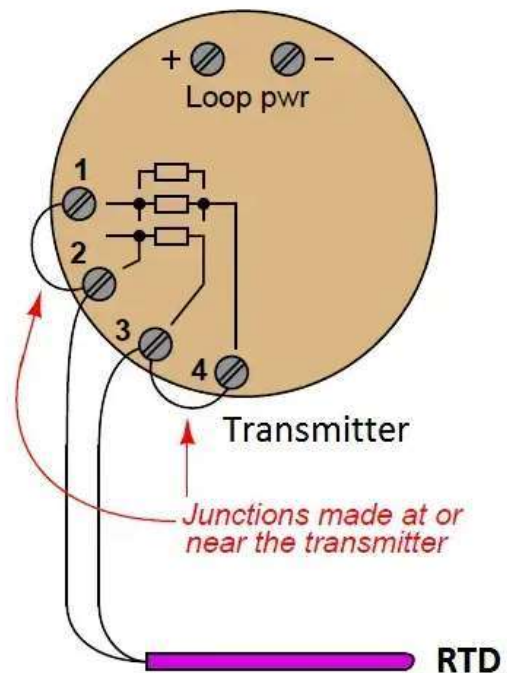

➤ TC (thermocouples):

It's a simple device consisting of two dissimilar wires joined at their ends, it generate (mv) when heat is applied to hot junction.

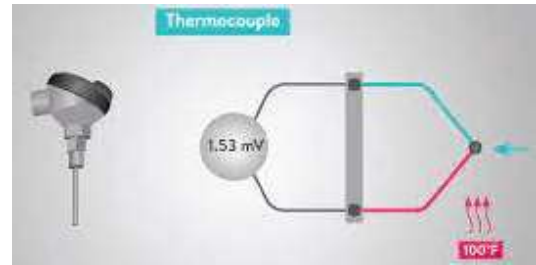

➤ Common Thermocouple Types

ANSI Code	ANSI MC 96.1 Color Coding		Alloy Combination		Maximum T/C Grande temp. range	EMF(mv)Over Max.temp.range	IEC 584-3 Color Coding	IEC Code
	Thermocouple	Extension	+ Lead	- Lead				
<b>K</b>			NICKEL-CHROMIUM Ni-Cr	NICKEL-ALUMINUM Ni-Al	-270 to 1372°C -454 to 2501°F	-6.458 to 54.888		<b>K</b>
<b>J</b>			IRON Fe (magnetic)	CONTANTAN COOPER-NICKEL Cu-Ni	-210 to 1200°C -346 to 2193°F	-8.095 to 89.553		<b>J</b>
<b>T</b>			COPPER Cu	CONTANTAN COOPER-NICKEL Cu-Ni	-270 to 400°C -454 to 752°F	-6.258 to 20.872		<b>T</b>
<b>E</b>			NICKEL-CHROMIUM Ni-Cr	CONTANTAN COOPER-NICKEL Cu-Ni	-270 to 1000°C -454 to 1832°F	-9.835 to 76.373		<b>E</b>
<b>N</b>			NICROSIL Ni-Cr-Si	NISIL Ni-Si-Mg	-270 to 1300°C -450 to 2372°F	-4.345 to 47.513		<b>N</b>
<b>S</b>	NONE ESTABLISHED		PLATINUM-10% RHODIUM Pt-10%Rh	PLATINUM Pt	-50 to 1768°C -58 to 3214°F	-0.236 to 18.693		<b>S</b>
<b>R</b>	NONE ESTABLISHED		PLATINUM-13% RHODIUM Pt-13%Rh	PLATINUM Pt	-50 to 1768°C -58 to 3214°F	-0.226 to 21.101		<b>R</b>
<b>B</b>	NONE ESTABLISHED		PLATINUM-30% RHODIUM Pt-30%Rh	PLATINUM-6% RHODIUM Pt-6%Rh	0 to 1820°C 32 to 3308°F	0 to 13.820		<b>B</b>

International Type Designation	Conductor Material	Temperature range (°C)
K	Ni-Cr (+)	0 to +1100
	Ni-Al (-)	
T	Cu (+)	-185 to +300
	Cu-Ni (-)	
J	Fe (+)	+20 to +700
	Cu-Ni (-)	
E	Ni-Cr (+)	0 to +800
	Cu-Ni (-)	
N	Ni-Cr-Si (+)	0 to +1250
	Ni-Si (-)	

➤ Reference(cold) junction:

- ❖ Tc has two junctions; the difference is temperature of these junctions is what is used to measure temperature.
- ❖ Cold junction is located in a transmitter or signal conditioner.
- ❖ The voltage measured at cold junction directly affects the temperature difference between the hot & cold junction.
- ❖ Therefore, the temperature at cold junction should be known; and the process to determine exact cold junction temperature is known as (cold junction compensation).
- ❖ cold junction compensation can be performed by either the temperature transmitter, TC input card for DSC or PLC, alarm trip or other signal conditioner.

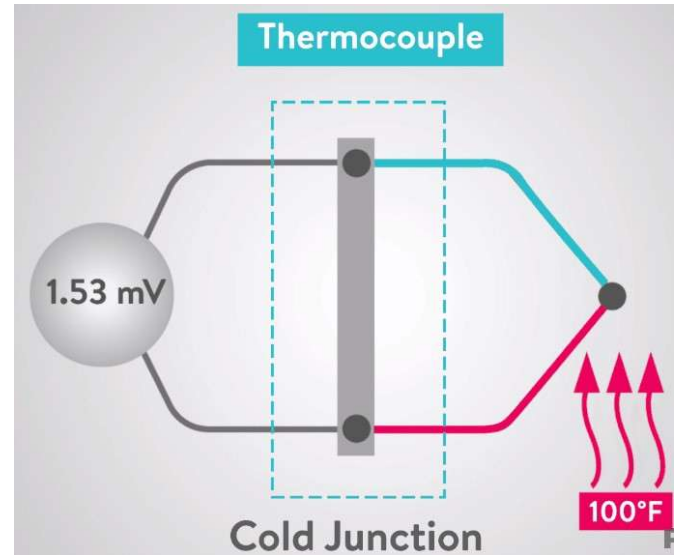

# The simplest case occurs when the cold junction is at 0°C, also known as an ice-bath reference. If  $T_c = 0^\circ\text{C}$ , then  $V_{OUT} = V_H$ . In this case, the voltage measured at the hot junction is a direct translation of the actual temperature at that junction.

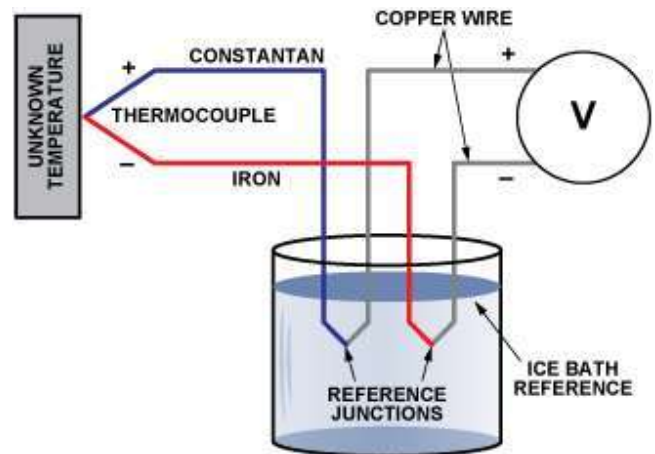

$$V_{out} = V_H - V_C$$

$$= \alpha (T_H - T_C)$$

The scale factor ( $\alpha$ ) which relates the voltage difference to the temperature difference, is known as the Seebeck coefficient.

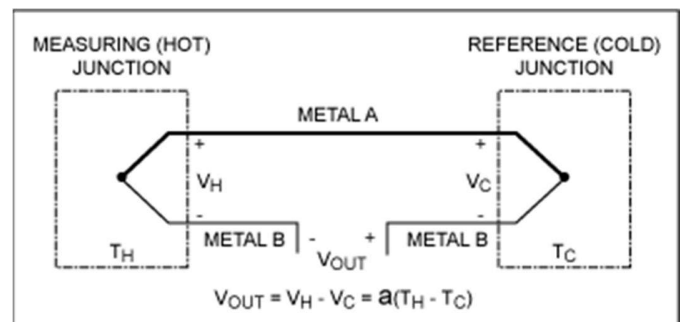

➤ **Do I need an RTD Sensor or a Thermocouple?**

Whether you choose a thermocouple or an RTD Pt100 sensor depends on the application and measurement requirements (accuracy, speed of response, temperature range etc.) of the user. It is not a case of one being better than the other as both thermocouples and RTD Sensors have their own merits and uses.

**Temperature Range:** Thermocouples have a wider temperature range than RTD Sensors, with some able to measure temperatures up to 2900°F and beyond. For most industrial applications RTD Sensors are limited to 1100°F and more often to 480°F.

**Accuracy:** If high accuracy is of most importance, then a Pt100, which is the most common RTD sensor in general use, is the better choice.. Even the least accurate Pt100 (Class B) will usually be more accurate than a thermocouple. Pt100s are available with very high accuracies, 1/10 DIN elements for example, have an accuracy of  $\pm 0.03^{\circ}\text{C}$  at  $0^{\circ}\text{C}$ .

**Stability:** Thermocouples tend to drift over time due to chemical changes such as oxidation, whereas measurements from RTD Pt100 sensors are stable and repeatable if the sensor is kept within the temperature range of the RTD sensor.

**Response Times:** Whilst ever smaller diameters have improved RTD response times considerably, thermocouples, especially with a grounded or exposed junction, are still very much faster in response to changes in temperature.

**Durability:** Because of the more fragile nature of Pt100 elements, thermocouples are considered more rugged and durable especially for high vibration applications where Pt100 sensors are not suitable. In summary, a thermocouple is a simple rugged sensor that can withstand significantly more mechanical abuse than a Pt100.

**Cost:** Thermocouples are generally less expensive to manufacture and have lower material costs, except for the cabling where thermocouple wires are slightly more expensive than the copper wires used for RTD sensors.

**Advantages and Disadvantages of RTD Sensors and Thermocouples**

Sensor Type	Advantages	Disadvantages
<b>RTD Pt100</b>	High Accuracy High stability Highly repeatable	Passive Low vibration resistance Slower response Low range ( Motor winding)
<b>Thermocouple</b>	Wide Temperature Range(Boiler) Fast response Very small size Low cost	Less accurate Less stable Long term drift

## ➤ Temperature Gauge:

A temperature gauge is a device used for the accurate measurement and reading of temperature gradient. The term temperature gauge usually, though not always, refers to a device showing readings on a numbered dial.

Dial thermometer gauges are often found in industrial and commercial settings. They are also common in certain everyday domestic settings and appliances.

Temperature measurement gauges fall into two broad categories - contact thermometers, and non-contact thermometers. People often buy a temperature gauge to help monitor ambient temperatures at the mounting location. These are non-contact sensors.

Certain types of contact temperature gauge are also designed to be coupled with a probe or thermistor. These can then be used to check the surface or inner temperature of an object or medium they are in direct contact with, such as a water temperature gauge.



Analog

Digital



Temperature gauges measure the thermal state of a homogeneous substance. The measuring system must be brought as closely together as possible with the body to be measured. The most widely used measuring methods for temperature measurement rely on temperature-dependent characteristics of the body and substance.

## ➤ Temperature Switch:

A mechanical device that is used to monitor and control the temperature in manufacturing and industrial processes by turning ON & OFF switch contacts once a fixed temperature range is reached is known as a temperature switch.

This switch is a small and cost-effective solution to measure temperature within moveable & space-constrained applications. The temperature switch symbol is shown.



The switching condition of these switches mainly changes based on the input temperature. So this function is used as protection from overheating. So, these switches are mainly responsible for monitoring the temperature of equipment & machinery.

## Temperature Switch Construction

The different components used in this switch mainly include switch case, range nut, range spring, main spindle, bellows, capillary, and temperature sensing bulb. The construction diagram of the temperature switch is shown below.

As shown in the above diagram, the fluid within the temperature sensing bulb responds to variations in temperature. Once temperature increases, the pressure within the bellows increases. So the increase in the temperature sensing bulb will compress the bellows & moves the spindle up until the force of spring as well as the pressure of bellows are in equilibrium. The spindle movement is moved toward the switch & causes ON & OFF action based on the set point of the switch.

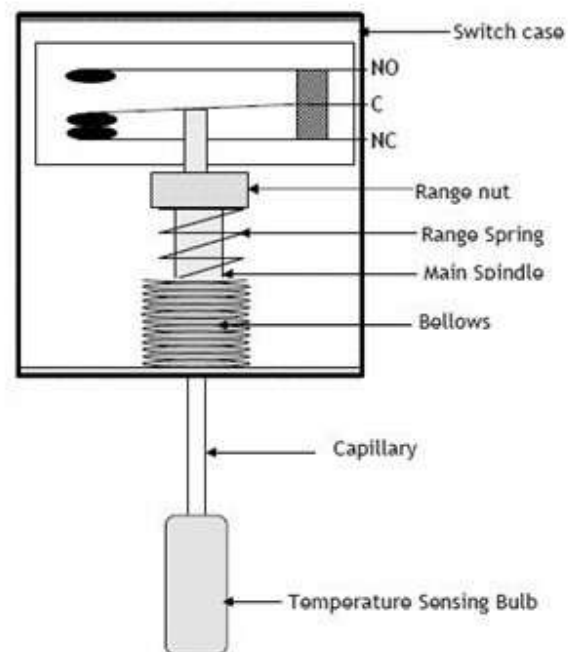

## Working Principle

The working of a temperature switch mainly depends on the variations of temperature taking place within an enclosed space. The function of a temperature switch is to trigger when changes in temperature occur.

Once the sensing probe in this switch detects an increase in temperature, then it opens the electric contacts. Similarly, if the switch detects a decrease in temperature then electrical

contacts will be closed. So these variations in temperature can be used to activate a switching mechanism.

## Specifications

The temperature switch specifications include the following:

- Voltage supply ranges from 12 to 30VDC.
- Its accuracy is  $\pm 0.1\%FS$   $\pm 0.3\%FS$   $\pm 0.5\%FS$ .
- Pressure resistance typically min 40bar to maxi 300bar.
- Long-term stability (1 year):  $\pm 0.1\%FS$
- Response time  $T=90^{\circ}C$  at 5.4s and  $T=50^{\circ}C$  at 2.3s.

## Temperature Switch Types

These switches are categorized into two types mechanical temperature switches and electronics temperature switches.

### Mechanical Temperature Switches

Mechanical temperature switches are available in two types bimetallic and liquid expansion temperature switches which are used for measuring or detecting the change in temperature.

The advantages of a liquid expansion thermometer include less cost, compact size, and more accurate whereas the disadvantages are; that response time is high, leakage occurs, resistant to temperature & shock, etc.

### Electronic Temperature Switch

This temperature switch mainly includes a power supply source, measuring element, and electronic circuit. This switch is used to measure temperature by changing it into a switching signal through the change in temperature of the measuring element. This switching signal changes in proportion to the temperature & can be calculated accordingly. Electronic temperature switches are applicable where high accuracy is necessary.

## Temperature Switch Vs Thermostat

The difference between a temperature switch and a thermostat includes the following:

Temperature Switch	Thermostat
The temperature switch is also known as a thermal switch.	The thermostat is also known as an indicator or thermometer.
The main function of this switch is to measure temperature.	A thermostat device's function is to regulate temperature,
This switch is a bi-stable electromechanical device.	This is a closed-loop control device.
Generally, these switches are classified into two types electronic and mechanical.	Thermostats are classified into three types programmable, non-programmable and smart.
This switch includes two main parts like sensing part and snap-action contacts.	The thermostat includes different parts like flange, frame, housing, and wax element.

### What is the Purpose of Temperature Switch?

The main purpose of the temperature switch is to monitor the temperature of machinery & equipment. These are used to limit temperature in industries and protect machinery from overheating.

### What is the Deadband of Temperature Switch?

The deadband of the temperature switch is the difference within temperature between the increased set point & decreased set point.

### Are Temperature Switches Normally Open or Closed?

When the temperature switch is Normally Open (NO), then the switch contacts are NO normally open at minimum temperature. Similarly, Normally Closed (NC) means that the switch contacts are NC at minimal temperature.

This switch gets activated by a change in temperature & changes its condition from NO to close or from NC to open. The NO thermal switch contacts usually stay open which will close with the increase in temperature.

### Simulating thermocouples and RTDs for calibration and testing :

Thermocouples and RTDs are the most common sensors used in process temperature measurements.

Simulating a process sensor signal into a process instrument or control system input enables a technician to verify whether the device responds correctly to the temperature measured by the instrument. There are many ways to perform RTD and thermocouple simulation for testing purposes.

You can use a mV dc source and a mV vs temperature look up table for simulating thermocouples or a resistance decade box and resistance vs temperature look up table for simulating RTDs. This method, however, has become outdated with modern temperature calibrators that do the conversion for the user. With modern calibrators, simply select the sensor type to simulate, input the temperature to source and connect to the devices under test.

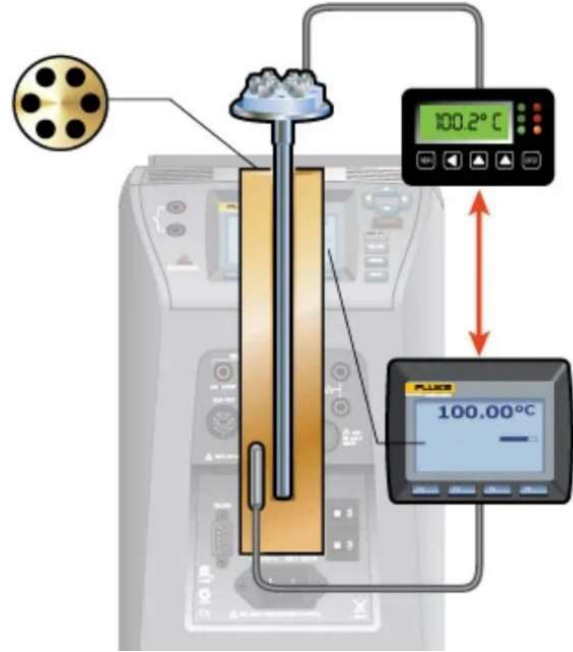

### How to perform the test via RTD and thermocouple simulation?

To use a thermocouple simulator to test a device with a thermocouple input:

1. Disconnect the process measurement sensor and connect the test connection wires in its place (Figure A).
2. Connect the mini connector from the test wires to the TC source connection of the calibrator.
3. Connect a DMM or other measurement tool to the tested device's mA output.
4. Verify the devices range or span. Apply the 0% value with the simulator and verify with the DMM that the output mA value or voltage is as expected.
5. Repeat the test, applying the 50% and 100% temperature signals.
6. If the measured output of the device is within limits, the test is complete. If not, adjust the device at zero (offset, 0%) and span (gain, 100%).
7. Repeat steps 4 and 5 and verify for a correct response.

To use an RTD simulator to test a device with an RTD input:

1. Connect the calibrator to the device input as shown in figure B.
2. Connect the calibrator output with the right combination to match the device configuration (2, 3 or 4-wire).
3. Use the test procedure at left for thermocouple testing, starting at step 3.

## Temperature transmitter calibration

The performance of temperature transmitters and related instruments can decline, especially in the harsh environments found in industrial settings. Temperature transmitter calibration maintains reliability and uptime.

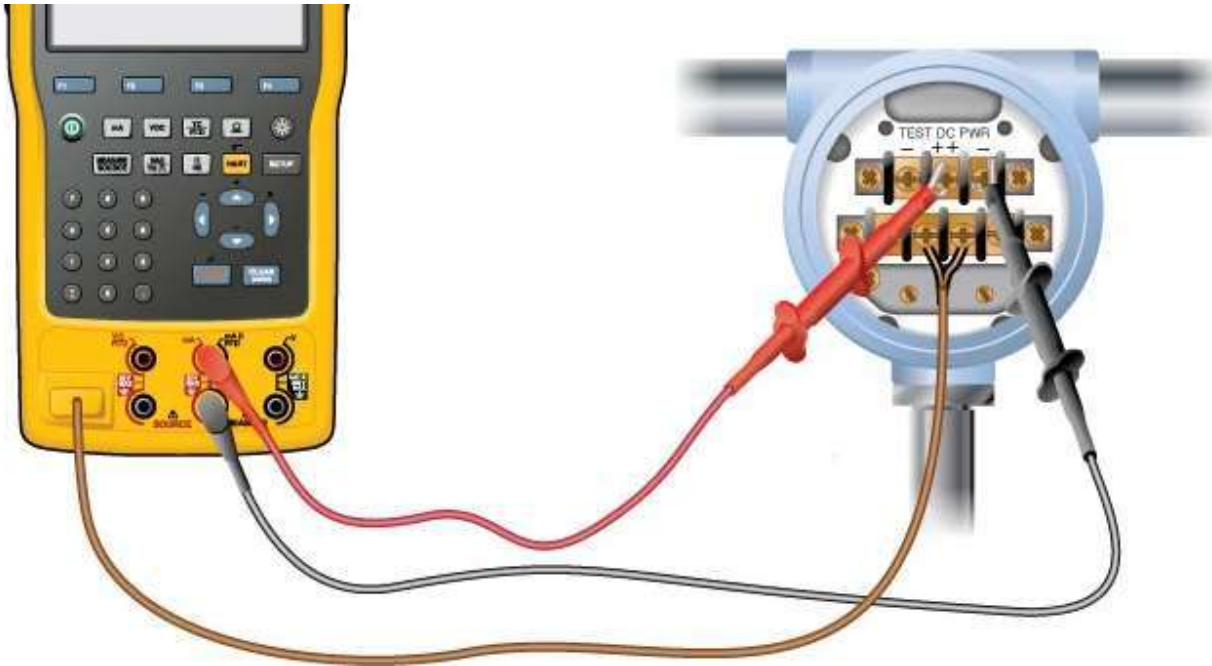

Fluke calibrators, such as the Fluke 724 Temperature Calibrator or the Fluke 754 Documenting Process Calibrator, can provide the three things necessary to accurately calibrate a temperature transmitter – sourcing temperature, providing loop power and measuring the resulting output current.

Most advanced documenting process calibrators, such as the Fluke 754, can also test and calibrate both temperature and pressure instruments, which keeps the number of instruments a technician needs to carry to a minimum. The 754 can even calibrate the most-used tasks of HART electronic instrumentation, including pulsed instruments such as RTD transmitters. A calibrator combined with a dry well such as the Fluke Calibration 9142 Field Metrology Well provides a complete closed-loop solution.

When comparing calibrators, the traceability of test equipment is also an important factor. Traceability means the calibration's test and measurement functions have been verified to perform within required specification and those specifications are traceable to national and international standards. All Fluke test equipment can be ordered with a NIST-traceable calibration.

## Calibrating a HART temperature transmitter

Calibrating a HART temperature transmitter requires an accurate temperature simulator or temperature source, mA measurement, and a HART communication tool for calibration. You can use separate tools or a calibrator that integrates all three to perform this task. HART is an industry standard defining the communications protocol between smart field devices and a control system that uses 4-20 mA wiring.

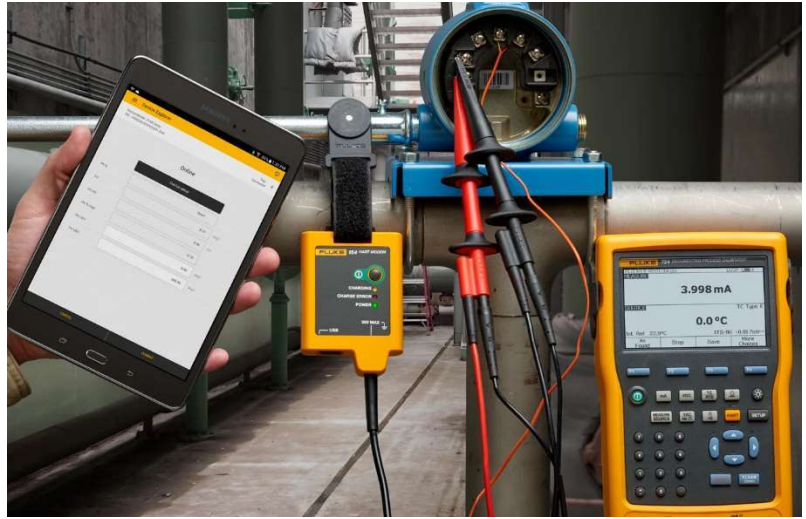

Before going to the field, gather the needed calibration and communication test tools. If testing an RTD transmitter, be sure to bring extra test leads for connections. Testing a 3-wire RTD requires five test leads—three for simulating the RTD sensor and two for measuring the mA signal. If using a separate communicator, you will need its test lead set as well. For thermocouple (TC) calibrations, be sure to have the correct TC test wire type with a mini-connector terminated with the correct TC connector type (i.e. Type K wires and connector to simulate a Type K thermocouple).

## Ensuring accuracy

Your mA measurement tool and temperature source calibrator should be at least four times more accurate than the device being tested. To make that determination, refer to the data sheets of both the transmitter and the calibrator being tested, and account for temperature and stability (time). The Fluke 754 Documenting Process Calibrator has the HART functionality built in to enable smart trims on transmitters. It can also document transmitter performance before and after adjustment and calculate pass/fail errors.

The Fluke 154 HART Communicator is a tablet-based HART communication tool that pairs with a documenting process calibrator or a multifunction process calibrator to give you a complete HART calibration and configuration solution.

## How to perform the test:

This example assumes that the transmitter is isolated from the process and is not electrically connected to a loop power supply. A separate 250-ohm resistor is not necessary because the Fluke 754 incorporates a resistor in series with the loop supply through its mA jacks. The 3144 in this example is configured for a type K thermocouple sensor with a span of 0 °C to 300 °C.

1. Select MEAS mA, SOURCE T/C type K to configure the calibrator to measure the analog mA output of the transmitter and source the correct temperature stimulus at the 3144 input. Press ENTER to select.
2. Press the As Found softkey, then press ENTER to select Instrument for a linear transmitter calibration. Fill in the appropriate test tolerance and press the Done softkey.
3. Press the Auto Test softkey to begin calibration. Once the test is complete, an error summary table is displayed. When done viewing the table, press the Done softkey. Press Done again to accept, or ENTER to change the tag, serial number or ID fields.
4. If the As Found test failed, then adjustment is necessary. Press the Adjust softkey. Select Sensor Trim and press ENTER. Select Perform user trim – both and press ENTER.
5. For best results, press LRV to apply the LRV for the Lower Trim value. Press Trim and then Continue to move to the Upper Trim. Press URV, then Trim, then Done. If the 3144 is used with the digital PV output, skip to step 7 and perform the As Left test. If the analog 4-20 mA output is used in the process, continue to step 6.
6. Select Output Trim and press ENTER. The value of the primary variable (PVAO) is in the upper right corner of the display. This is normally a 4-mA signal. The mA value is in the center of the display. Press Fetch to load the measured mA value. Press Send to send the value to the 3144 to trim the output section for the 4-mA value. Press Continue for the 20-mA trim and repeat this step.
7. After completing Output Trim, press Done and proceed with the As Left verification test. Press As Left. Press Done and then press Auto Test. On completion, an error summary table is displayed. If errors are highlighted, the test has failed, and further adjustment is required. Return to step 5 for adjustment of the 3144.

## ⑤ Level Measurements

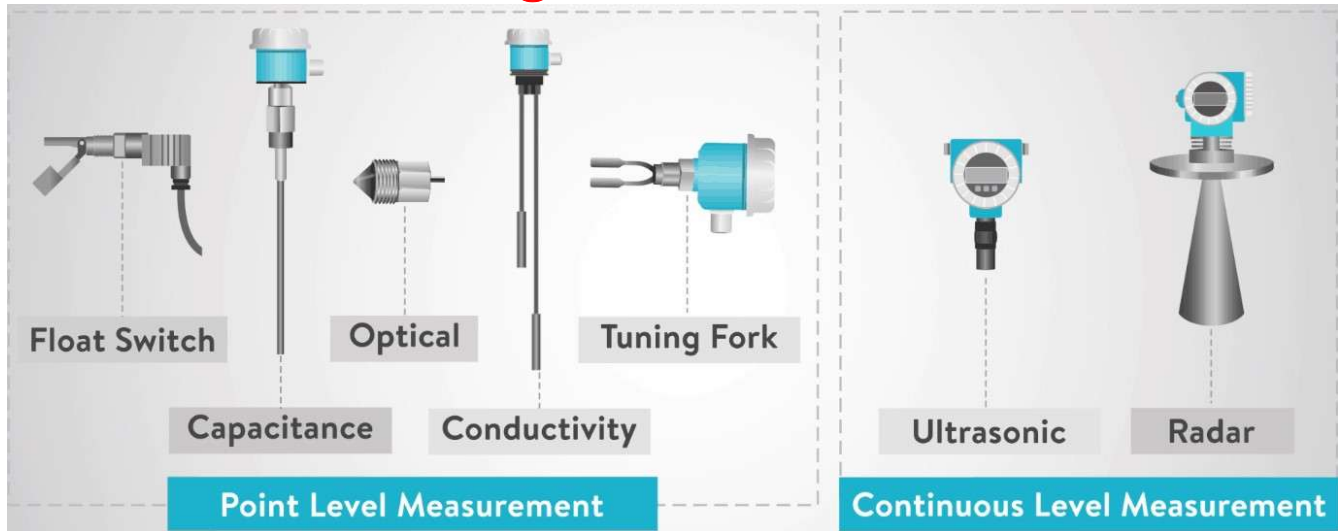

## Level measurement

### Point level

1. Float Switch
2. Capacitance
3. Optical
4. Conductivity
5. Tuning Fork
6. Magnetic

### continuous level

7. Ultrasonic
8. Radar
9. Displacer
10. Hydrostatic
11. Diff Pressure

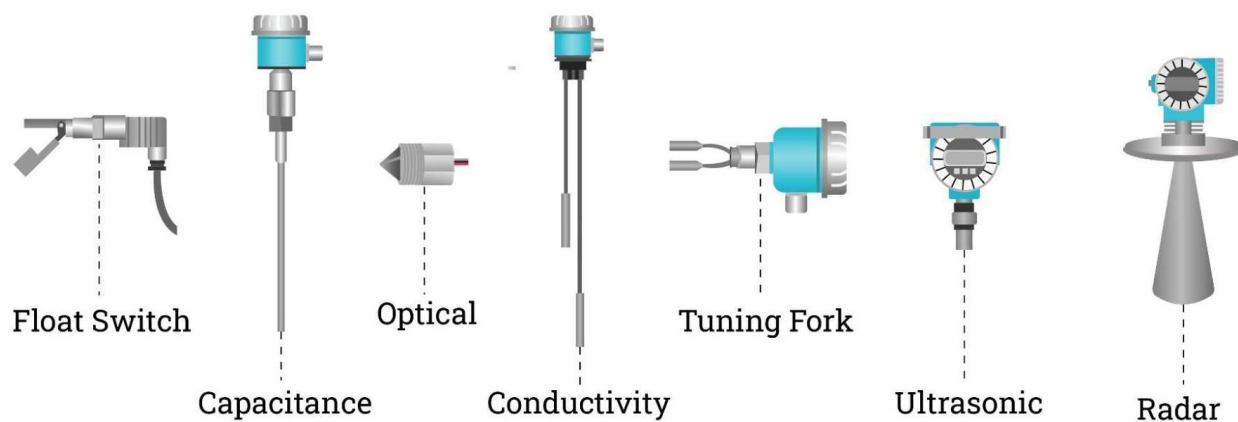

### ① Float Switch:

Float switches use a float, a device that raises or lowers when a product is applied or removed, opening or closing a circuit as the level rises or falls, moving the float.

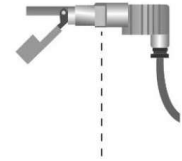

#### Advantages:

- Non – Powered.
- Direct indication.
- Inexpensive

#### Disadvantages:

- Must touch the liquid.
- Have moving Parts.
- Large in size.

### ② Capacitance:

A capacitance level sensor is a proximity sensor that emits an electrical field and detects a level based on the effect on its electrical field. (# low farad at empty tank)



#### Advantages:

- Small.
- Less expensive.
- Accurate.
- No moving parts.
- For liquids & Solids.

#### Disadvantages:

- Must touch the liquid.
- Have to be calibrated.
- Detect certain liquids.

### ③ Optical:

Optical sensors convert light rays(infra-red) into electrical signals, translating the physical quantity of light into a measurement.

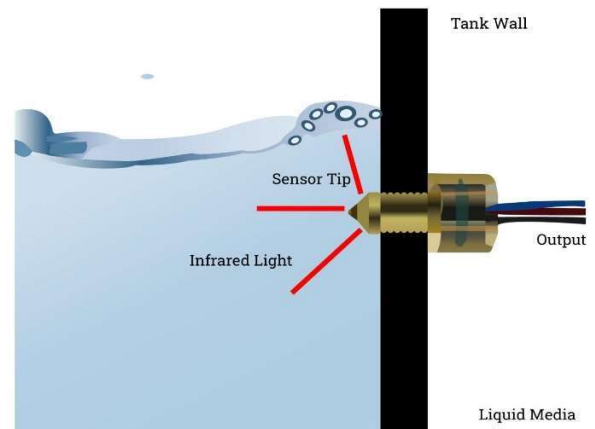

#### Advantages:

- Small.
- No moving parts.
- Can used in liquids
- Not affected by high pressure or temperature.

#### Disadvantages:

- Required cleaning.

#### ④ Conductivity:

A conductivity or resistance sensor reads conductivity with a probe. The probe has two electrodes and uses alternating currents to power them. When a liquid covers the probe, the electrodes connect to an electric circuit, causing current to flow and signaling a high or low level.

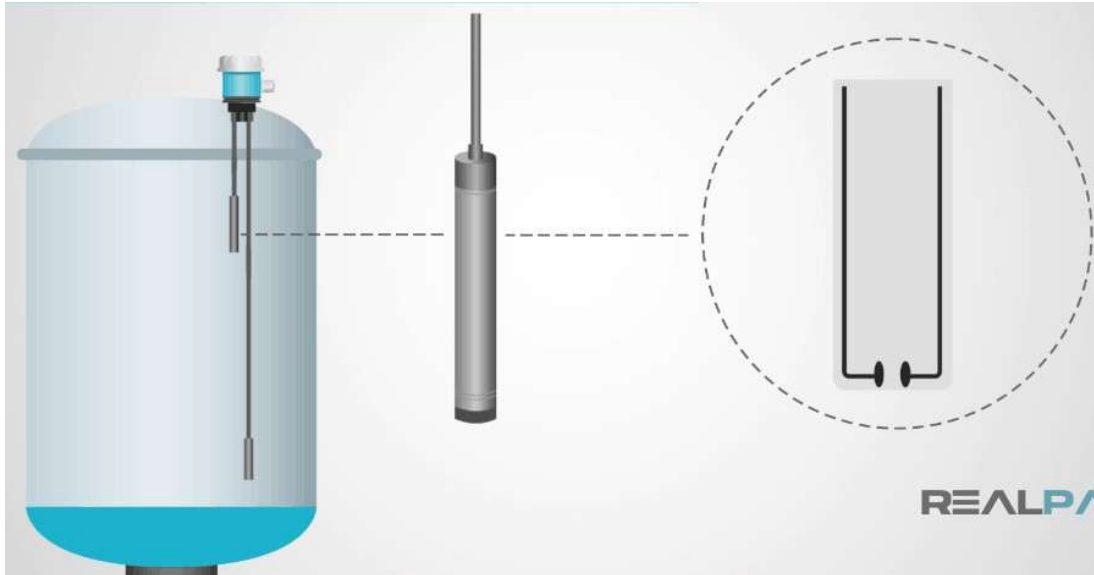

##### Advantages:

- Low cost.
- No moving parts.
- Easy to use.

##### Disadvantages:

- Must touch product.
- Only for conductive liquid.
- Probe will erode overtime.

#### ⑤ Tuning Fork:

They employ a sensing element in the shape of a fork with two tines. The fork vibrates at the frequency of its natural resonant frequency. Therefore, the frequency of the fork detecting the level will change as the level changes.

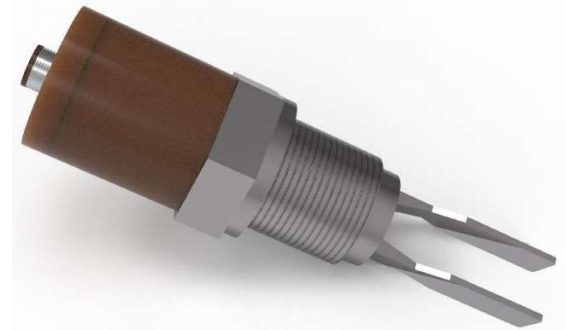

##### Advantages:

- Inexpensive and small.
- simple to install.
- used in the mining, food and beverage, and chemical processing industries.

##### Disadvantages:

- Must touch product.

## ⑥ Magnetic:

The strength of the magnetic coupling between the float and the indicator must be directly proportional to the distance separating them. We must not allow any dirt or debris in the chamber, it can be lodged between the float and the inner wall, and it could prevent the float from following the change in the liquid level so the measurement will be badly affected. The magnetic level indicator is designed for specific liquid density so if the float is not properly manufactured or the density of the process fluid changes then there will be an error in the measurement. We must not use the magnetic level indicator for the process fluid that has less specific gravity than that of the float.

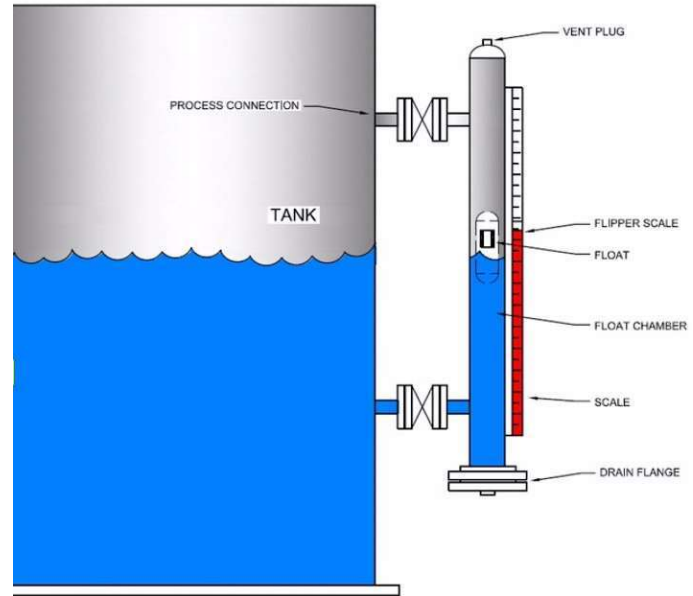

The magnetic level indicator must be made of stainless steel or other materials that could be compatible with the process fluid. The float must be selected according to the density of the liquid. The length of the magnetic level indicator must be suitable for the level range of the application. It must not be used for the liquid-liquid interface. We must make sure that the float and the chamber are designed according to the design pressure and temperature.

In a magnetic level, indicator floats are used to indicate the level, this type of level measurement is done with the attraction between two magnets. This device has a magnet that is enclosed in a float and it also has a second magnet which is called the magnet follower and it is in a non-ferrous metal tube. The magnet in the float attracts the magnet in the tube as the float raises and lowers with the level of the process liquid and this would cause the magnet inside the tube to raise and lower. By checking the position of the magnet the level of the liquid in the tank can be determined.

### Advantages:

- It is cheap
- Easy to install
- High accuracy
- It is not affected by material characteristics such as conductivity and dielectric constant.

Used for { Waste treatment , Chemical industry, petro-chemistry, Power stations, Food and beverage industry }

### Disadvantages:

- Must touch product.
- Need clean liquids.

## ⑦ Ultrasonic:

Ultrasonic-level sensors generate and receive ultrasonic waves using the time it takes to reflect and measure distance. Ultrasonic sensors have no moving parts, are compact, extremely reliable, non-invasive (non-contact), unaffected by the properties of the material they are sensing, and self-cleaning due to vibrations produced. They are, however, costly and may be affected by the environment.



# work by transmit & receive ultrasonic waves (  $\text{Time} \propto \text{Level}$  ).

### Advantages:

- Non-contact
- Self-cleaning
- used in Solid

### Disadvantages:

- More expensive.
- Negative effects of environment.
- Need to be calibrated (Zero Trim).

## ⑧ Radar:

These sensors use an antenna on the radar sensor to transmit microwaves. The product being sensed reflects these microwaves to the antenna, and the time between signal emission and reception is proportional to the product level. Radar sensors offer many benefits. They are not affected by temperature, pressure, or dust and can measure liquids, pastes, powders, and solids. They are also very accurate and do not require calibration, and they are non-invasive because they do not have to touch the product. They are, however, expensive and have a limited detection range. Radar sensors, like ultrasonic sensors, are ideal for hot liquid storage tanks. # work by transmit & receive high frequency electromagnetic waves (  $\text{Time} \propto \text{Level}$  ).

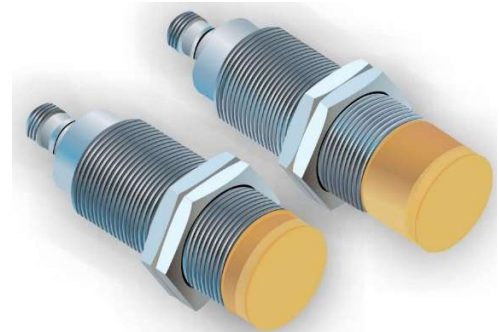

### Advantages:

- Accurate
- No Calibration.
- Non-touchable(Non-invasive).
- Non-affected by (Temp, Pressure or dust).
- Measure liquids , powders , solids.

### Disadvantages:

- More expensive.
- Limited detection range.



## ⑨ Displacer:

Displacer level sensor use Archimedes' Principle to observe liquid level by unendingly measurement the load of a displacer rod immersed within the process liquid.

The displacer is cylindrical in form with a continuing cross-sectional area and created long or short as needed. Normal heights range from fourteen inches to one hundred twenty inches.

As liquid level can increase, the displacer rod experiences a bigger buoyant force, creating it appear lighter to the sensing instrument, that interprets the loss of weight as a rise in level and transmits a proportional o/p signal.

As liquid level decreases, the buoyant force on the displacer rod decreases with a corresponding weight increase that is understood as decreasing level by the level detector that then provides a corresponding signal output.

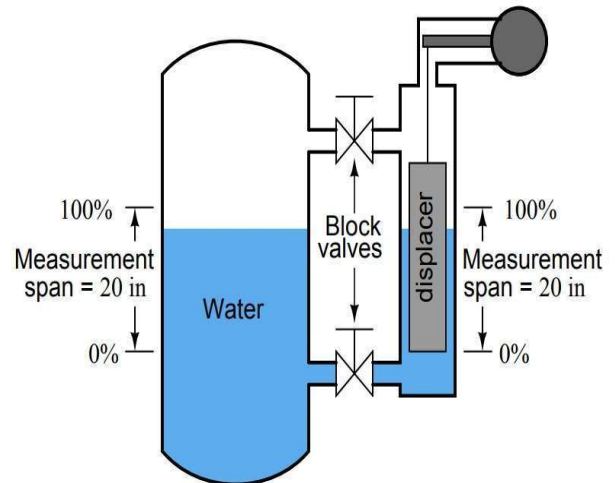
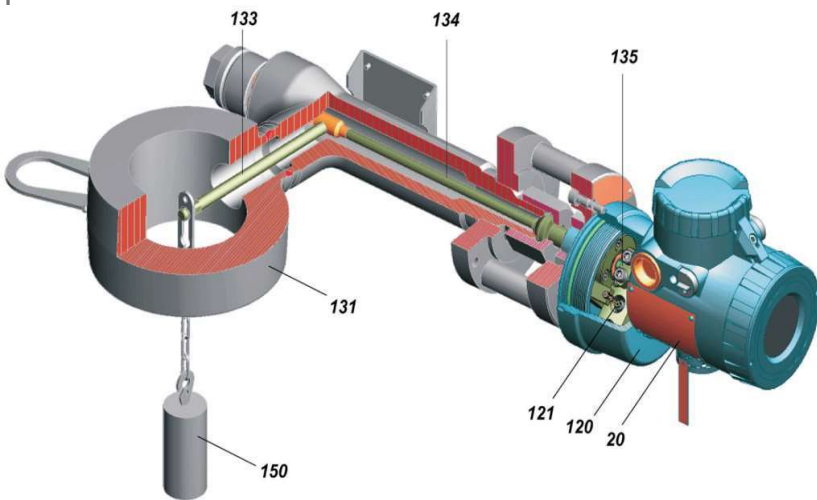
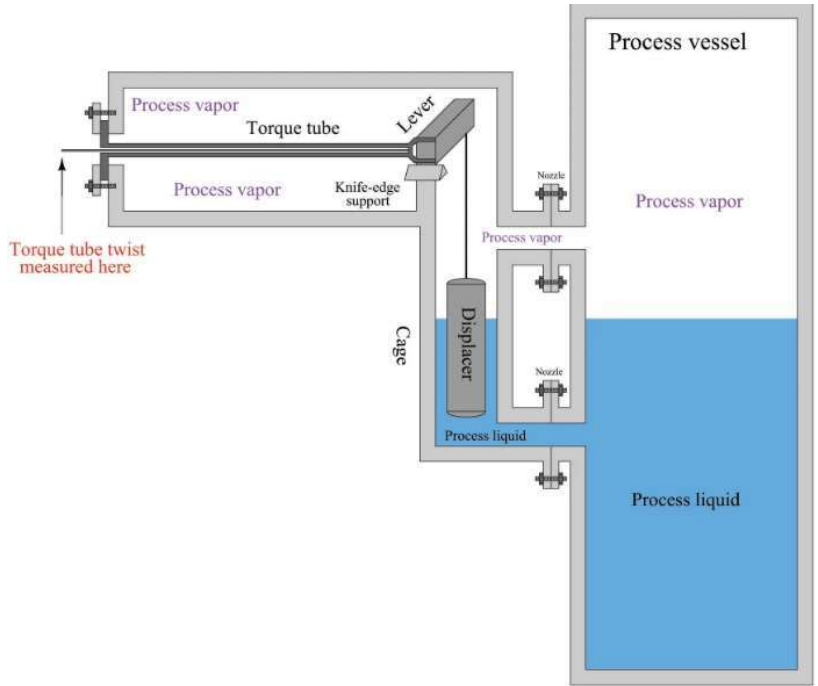

# Transmission level and torque tube transmit movement of the displacer and convert it rotor motion.

(RVDT) transfer it to electrical signal (4:20 mA).

RVDT : Rotary Variable Differential Transformer

## ➤ RVDT:

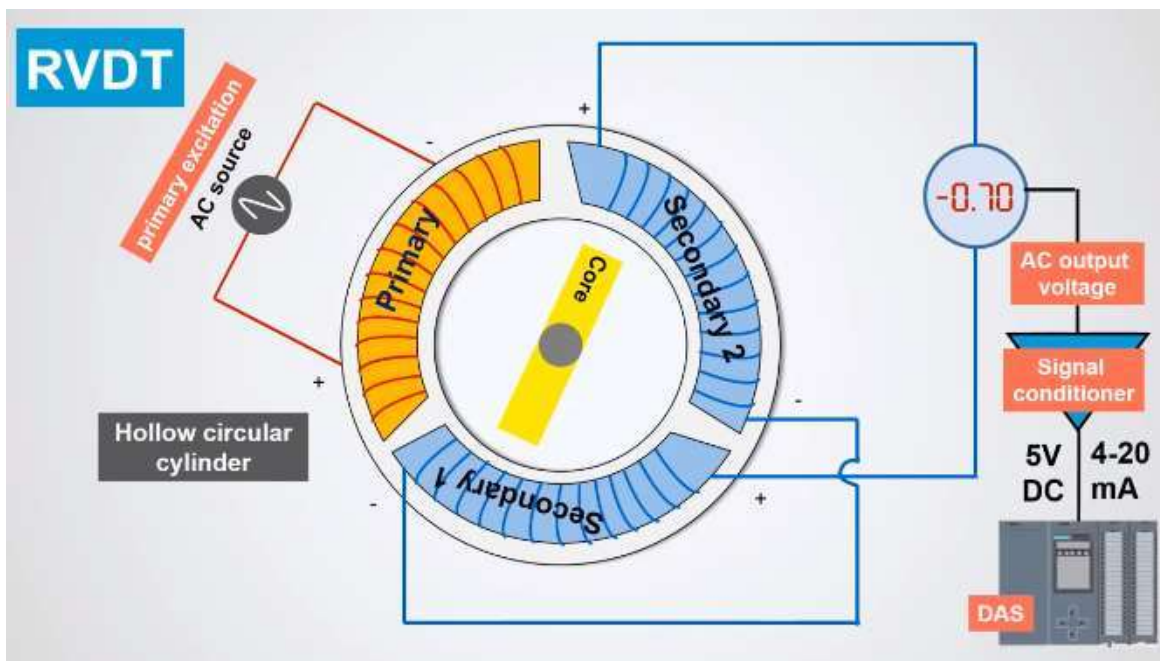

(RVDT) is an electro-mechanical transducer that provides a variable AC output voltage that is proportional to the angular displacement of its input shaft. As RVDT is an AC-controlled device, there is no electronic component inside it. Also, the electrical output of RVDT is obtained by the difference in secondary voltages of the transformer, so it is also called a Differential Transformer.

RVDT is an electro-mechanical inductive **transducer** that converts angular displacement into the corresponding electrical signal. It is the most widely used inductive sensor due to its high accuracy level. Since the coil of RVDT is designed to measure an angular position, it is also known as an **angular position sensor**. Unlike LVDT, RVDT is also a passive differential transducer.

The design and construction of RVDT is similar to LVDT. The only difference is the shape of the core in transformer windings. LVDT uses the soft iron core to measure the linear displacement whereas RVDT uses the Cam-shaped core (Rotating core) for measuring the angular displacement.

The working principles of RVDT and LVDT both are the same and based on the mutual induction principle. When AC excitation of (5-15) Volt at a frequency of 50-400 Hz is applied to the primary windings of RVDT a magnetic field is produced inside the core. This magnetic field induces a mutual current in secondary windings. Then due to transformer action, the induced voltages in secondary windings ( $S_1$  and  $S_2$ ) are  $E_{s1}$  and  $E_{s2}$  respectively. Hence the net output voltage will be the difference between both the induced secondary voltages.

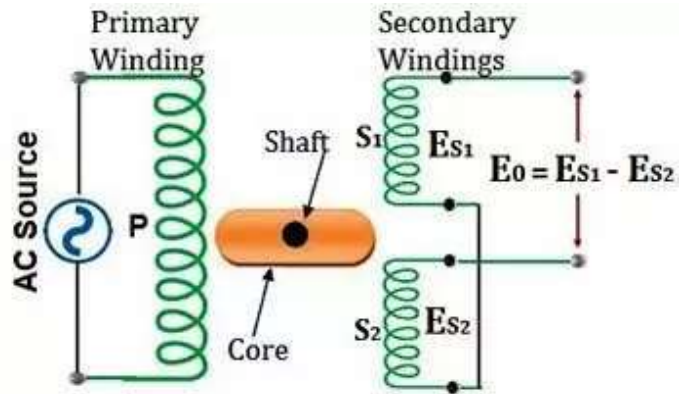

Hence Output will be  $E_0 = E_{s1} - E_{s2}$ .

Now according to the position of the core, there are three cases that arise. So Let's discuss these three cases one by one in detail.

- **Case 1: When the core is at the Null position:** When the core is at the null position then the flux linkage with both the secondary windings will be the same. So the induced emf ( $E_{s1}$  and  $E_{s2}$ ) in both the windings will be the same. Hence the Net differential output voltage  $E_0 = E_{s1} - E_{s2}$  will be zero ( $E_0 = E_{s1} - E_{s2} = 0$ ). It shows that no displacement of the core.
- **Case 2: When the core rotates in the clockwise direction:** When the core of RVDT rotates in the clockwise direction. Then, in this case, the flux linkage with  $S_1$  will be more as compared to  $S_2$ . This means the emf induced in  $S_1$  will be more than the induced emf in  $S_2$ . Hence  $E_{s1} > E_{s2}$  and Net differential output voltage  $E_0 = E_{s1} - E_{s2}$  will be positive. This means the output voltage  $E_0$  will be in phase with the primary voltage.
- **Case 3: When the core rotates in the anti-clockwise direction:** When the core of RVDT rotates in the anti-clockwise direction. Then, in this case, the flux linkage with  $S_2$  will be more as compared to  $S_1$ . It means the emf induced in  $S_2$  will be more than the induced emf in  $S_1$ . Hence  $E_{s1} < E_{s2}$  and Net differential output voltage  $E_0 = E_{s1} - E_{s2}$  will be negative. This means the output voltage  $E_0$  will be in phase opposition (180 degrees out of phase) with the primary voltage.

➤ **Displacement interface level measurement:**

Displacer level instruments may be used to measure liquid-liquid interfaces just the same as hydrostatic pressure instruments. One important requirement is that the displacer always be fully submerged (“flooded”). If this rule is violated, the instrument will not be able to discriminate between a low (total) liquid level and a low interface level. This criterion is analogous to the use of compensated-leg differential pressure instruments to measure liquid-liquid interface levels: in order for the instrument to solely respond to changes in interface level and not be “fooled” by changes in total liquid level, both process connection points must be submerged.

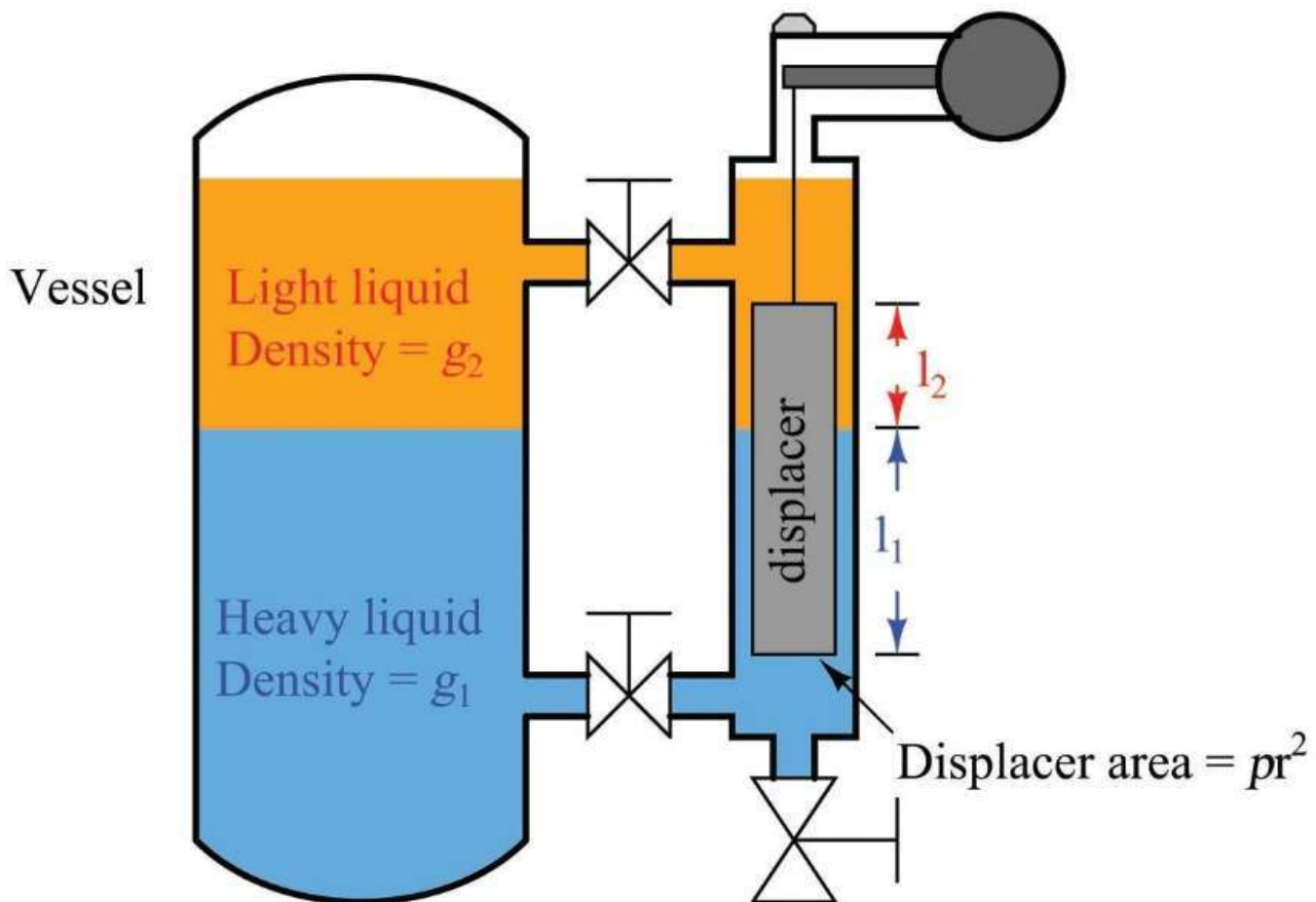

For example:

Light liquid has SG = 0.85 &&& Heavy liquid has SG = 1.1

SG: Specific gravity

The specific gravity of an object is the density of that object divided by the density of water. The density of water is 1,000 kilograms per meter cubed

## ⑩ Hydrostatic:

Hydrostatic pressure sensors are used for the measurement of level or filling height of a liquid. Hydrostatic pressure measurement is suited for level measurement due to the hydrostatic effect of non flowing fluids.

$$P = \rho gh$$

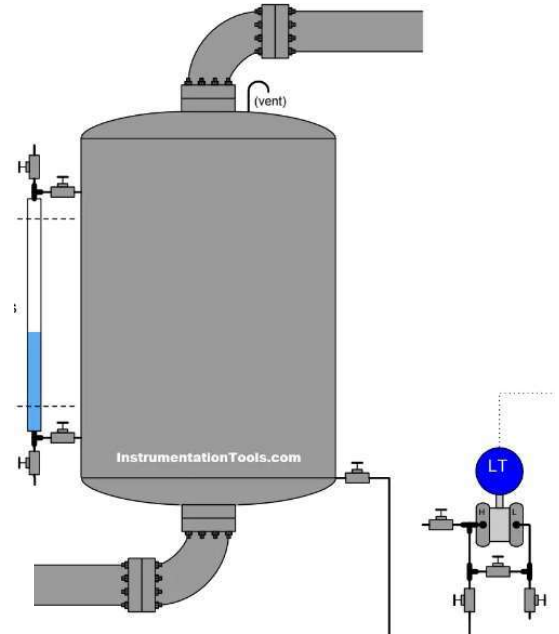
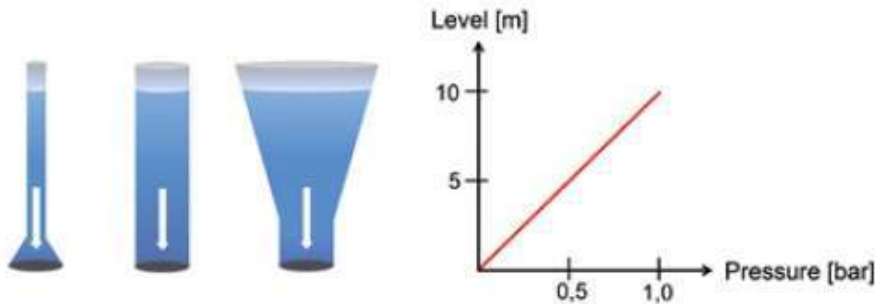

Hydrostatic pressure and level measurement enjoys a consistently high popularity due to its high robustness, high reliability and simple installation of this technology.

### Advantages:

- Highly Accurate (0.25%).
- Ideal for wide range of liquids.
- Ranges up to 30 M water.
- Used in sea water, oil, chemical, ...

### Disadvantages:

- Need to calibrate (**Span Setting**).
- Unsuitable for bulk material

**Note:** Accurate measurement requires either media with constant density or continuous density measurement of the medium

## ⑪ Differential Pressure:

Differential Pressure Transmitter can be used to measure the vessel level. We said earlier that the pressure at the bottom of a vessel is directly related to the level of the liquid in the vessel. In that case, if we connect a Differential Pressure Transmitter to the reference, or zero percent point of that vessel, we can use the pressure measurement to determine the level.

Another variable that has a major effect on the pressure at the reference point of the vessel is the relative density of the liquid in that vessel. Relative density is also called specific gravity.

There is a relationship between pressure, relative density, and liquid height. That relationship can be expressed as:

$$\text{Pressure (inches of water)} = \text{Relative density} \times \text{Liquid height (inches)}$$

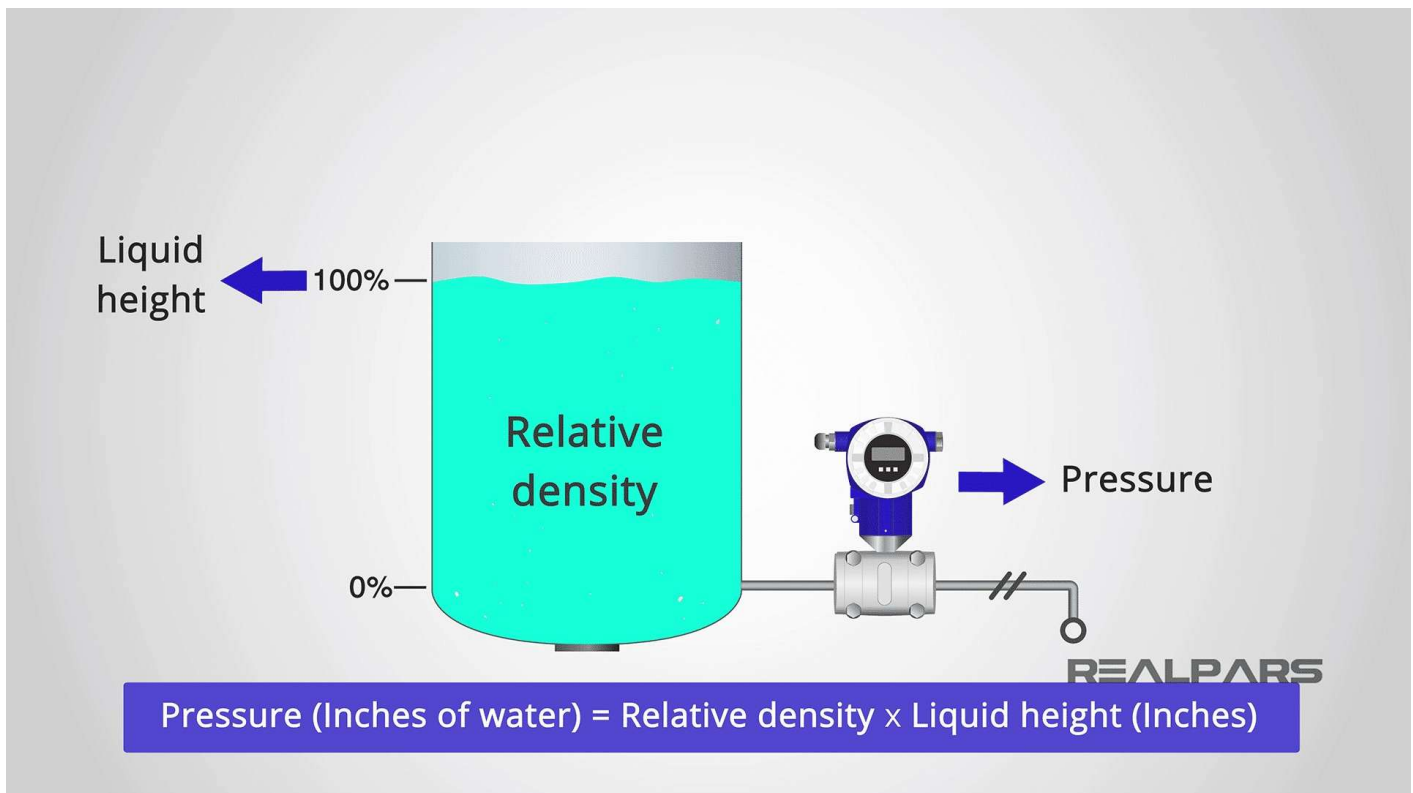

we can measure the level of an open vessel using a differential pressure transmitter

>>> The High-Pressure Port is connected at the 0 meters point and the Low-Pressure Port is vented to atmosphere.

## $\Delta p$ transmission

Open Vessel

Closed Vessel

Dry leg

Wet leg

At Zero level = 0 mmwc

At Span level =  $H \times \text{Specific gravity}$

= 500 mmwc

Then Range =  $500 - 0 = 500$  mmwc

So, we have to set Lower Range Value (LRV) = 0 mmwc and Upper Range Value (URV) = 500 mmwc in the DP Transmitter using HART communicator.

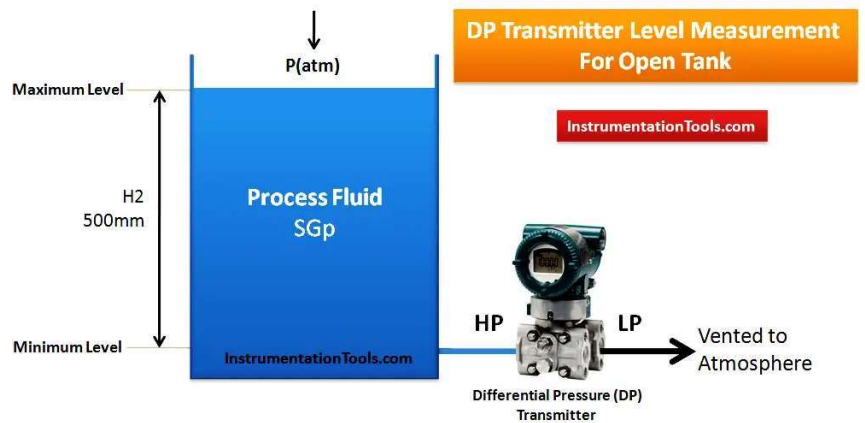

When zero suppression is used then H1 height always filled with process fluid.

At zero level (LRV) =  $H1 \times \text{specific gravity}$

=  $100 \times 1.0$

= 100 mmwc

At 100% level (URV) =  $(H1 + H2) \times \text{specific gravity}$

=  $(100 + 500) \times 1.0$

Range =  $URV - LRV = 600 - 100 = 500$  mmwc

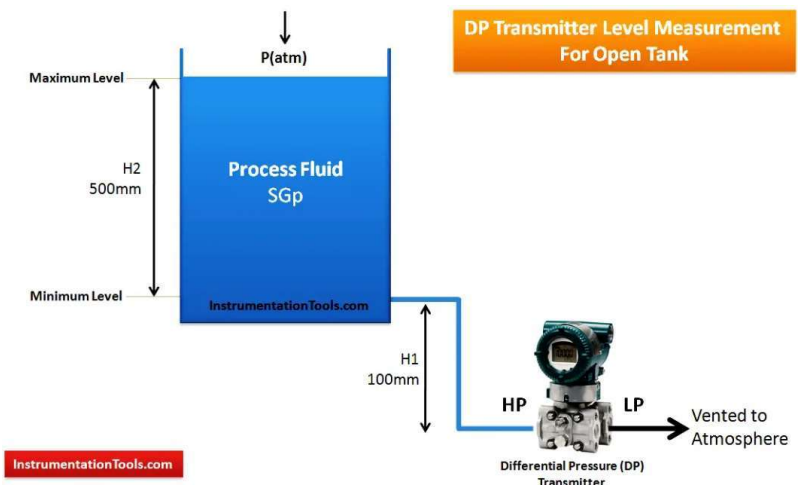

So, we have to set Lower Range Value (LRV) = 100 mmwc and Upper Range Value (URV) = 600 mmwc in the DP Transmitter using HART communicator.

## ➤ Closed Vessel:

- In closed tank DP level measurement, LP leg is connected to the top of tank.

There are two methods in closed tank DP Level Measurement.

### Dry leg method:

- Dry leg method is used in normal close tank where vapor is not condensate and temperature of process is equal to atmospheric.
- Simply when LP side of the DP transmitter is filled with any gas/air then we call it as Dry Leg & we apply Dry Leg Method for calculations.

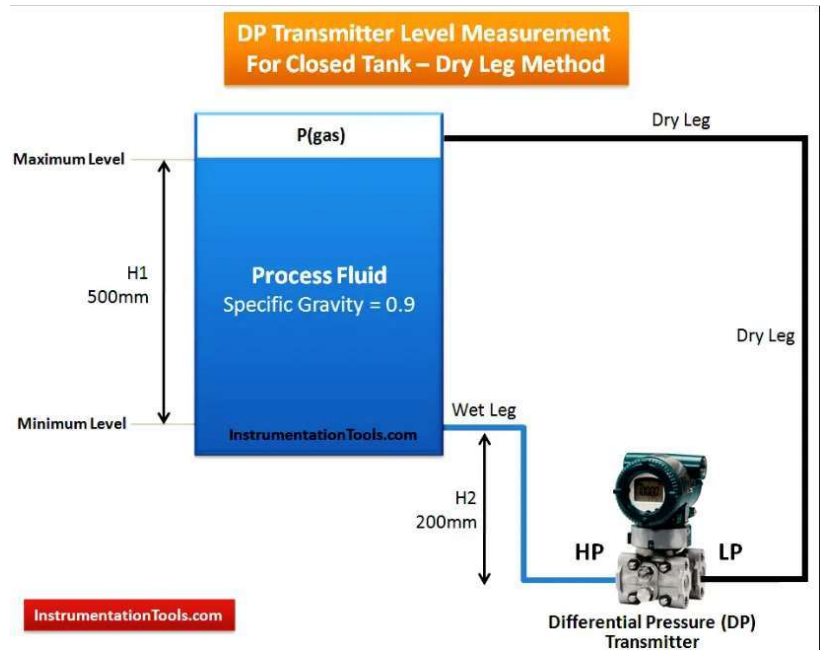

$$\begin{aligned} \text{At zero level (LRV)} &= \text{pressure acting on HP leg} - \text{Pressure acting on LP leg} \\ &= H2 \times \text{specific gravity} - 0 \\ &= 200 \times 0.9 - 0 \\ &= 180 \text{ mmwc} \end{aligned}$$

$$\begin{aligned} \text{At 100 \% level (URV)} &= \text{pressure acting on HP leg} - \text{Pressure acting on LP leg} \\ &= (H2 + H1) \times \text{specific gravity} - 0 \\ &= (200 + 500) \times 0.9 - 0 \\ &= 630 \text{ mmwc} \end{aligned}$$

$$\text{Range} = \text{URV} - \text{LRV} = 630 - 180 \text{ mmwc} = 450 \text{ mmwc}$$

So, we have to set Lower Range Value (LRV) = 180 mmwc and Upper Range Value (URV) = 630 mmwc in the DP Transmitter using HART communicator.

### Wet leg method:

Wet leg method is used where vapor has a tendency to make the condensate and temperature of process is high or low from the atmospheric.

- For DP Transmitter Configuration, we have to find out Zero Level & Span Level. Accordingly, we have to configure Lower Range Value (LRV) and Upper Range Value (URV) using HART communicator.

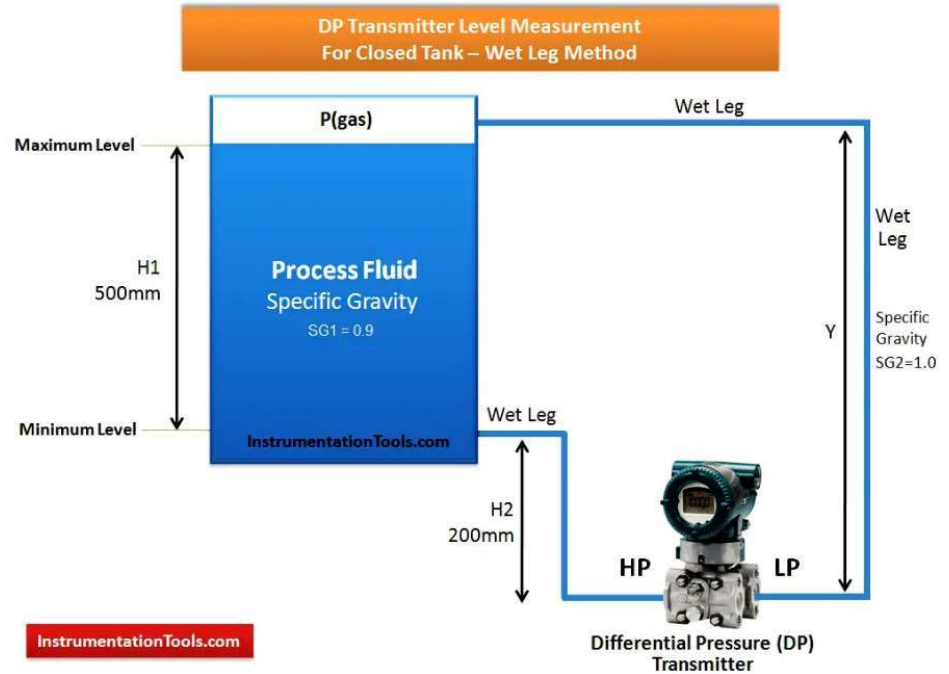

$$Y = H1 + H2 = 500 + 200 = 700 \text{ mm}$$

$$\begin{aligned} \text{At zero level (LRV)} &= \text{pressure acting on HP leg} - \text{Pressure acting on LP leg} \\ &= H2 \times SG1 - Y \times SG2 \\ &= 200 \times 0.9 - 700 \times 1.0 \\ &= 180 - 700 \\ &= -520 \text{ mmwc} \end{aligned}$$

$$\begin{aligned} \text{At 100 \% level (URV)} &= \text{pressure acting on HP leg} - \text{Pressure acting on LP leg} \\ &= (H2 + H1) \times SG1 - Y \times SG2 \\ &= (200 + 500) \times 0.9 - 700 \times 1.0 \\ &= 630 - 700 \\ &= -70 \text{ mmwc} \end{aligned}$$

$$\text{Range} = \text{URV} - \text{LRV} = -70 - (-520) = 450 \text{ mmwc}$$

So, we have to set Lower Range Value (LRV) = -520 mmwc and Upper Range Value (URV) = -70 mmwc in the DP Transmitter using HART communicator.

➤ **Differential Pressure Transmitter with 5 Way Manifold Valve:**

Some differential pressure transmitters are equipped with 5 way valve manifolds. These valve networks allow for blocking, equalizing, and bleeding of the transmitter's two pressure ports, the valves being arranged in this pattern:

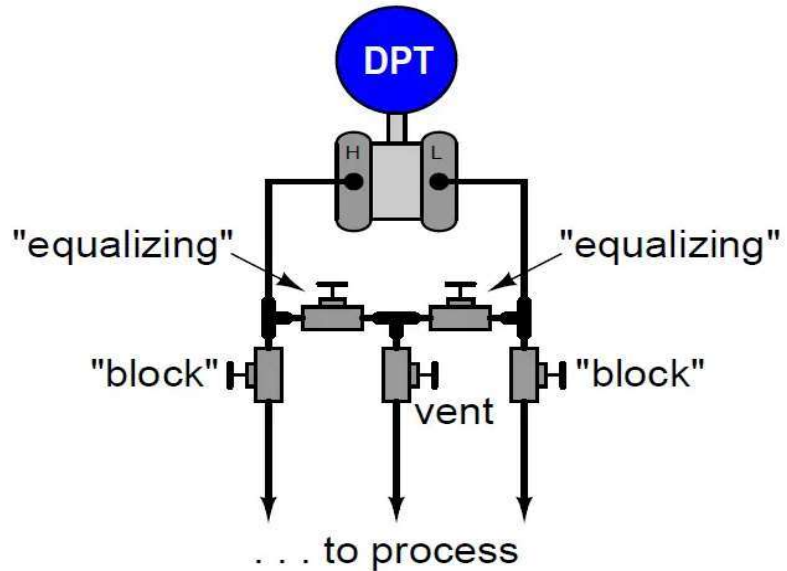

✚ **What can be done with this manifold that cannot be done with a three-valve manifold?**

❖ **Normal valve positions:**

- Both block valves open.
- Both equalizing valves closed.
- Vent valve closed.

**Normal operation**

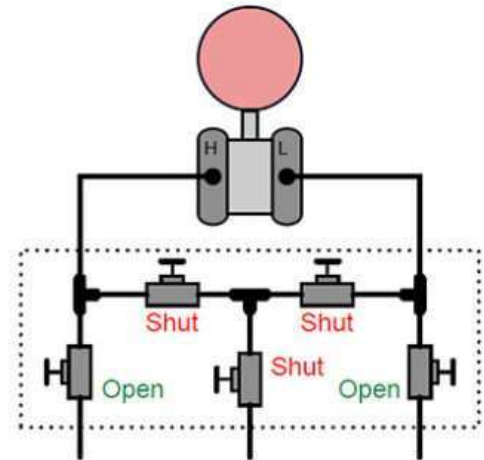

❖ **Removing differential pressure transmitter from service:**

- Close one block valve.
- Open both equalizing valves (which one first does not matter).
- Close the other block valve.
- Open the vent valve.
- Tag all valves, notifying of transmitter's planned return time/date.
- Disconnect the transmitter from the manifold.

**Removed from service**

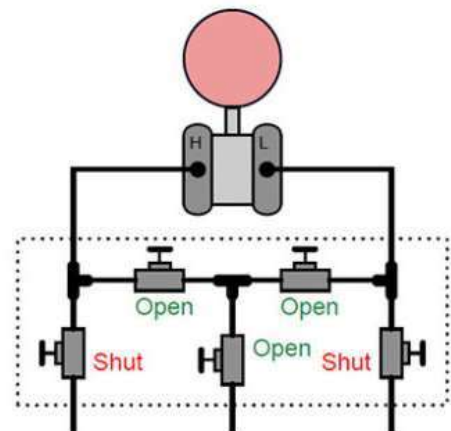

Restoring the transmitter back to service is as simple as reversing all the steps taken to remove it from service (i.e. go through the list backwards, doing the reverse of each instruction).

❖ *Difference between 5-valve manifold and 3-valve manifold?*

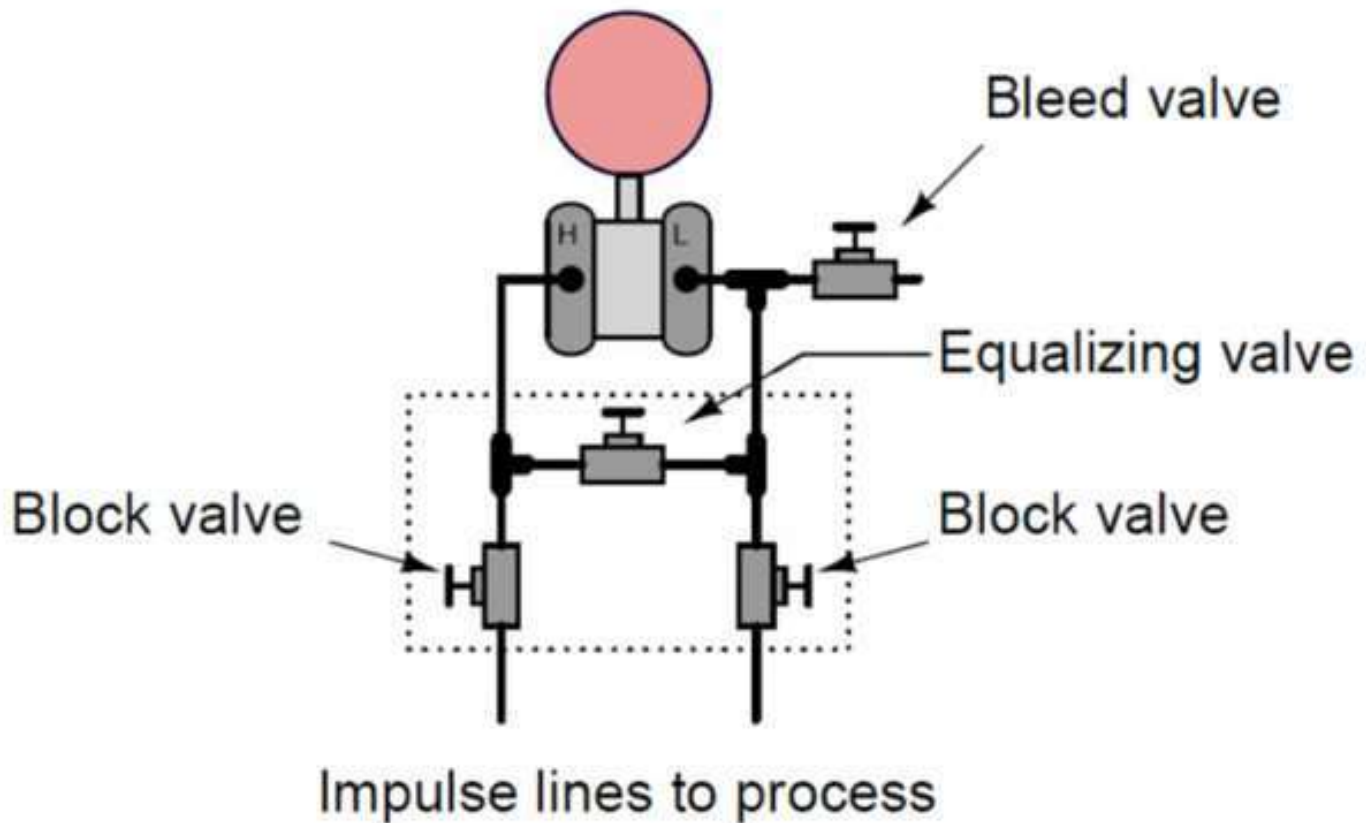

One feature that 5-valve manifolds provide over 3-valve manifolds is the ability to route a vent tube to a remote (safer) location, for use with particularly hazardous process fluids.

5-valve manifolds allow for in-place transmitter calibration, provided one of the  $\Delta P$  transmitter's sides has an atmospheric vent. By connecting the calibrating pressure source to the vent line, one can route the calibrating pressure to either side of the transmitter (only), while keeping the other side vented.

## ⑥ Flow Measurements

- A flow meter is an flow instrument that is used to indicate the amount of liquid, gas, or vapor moving through a pipe or conduit by measuring linear, non-linear, mass, or volumetric flow rates. Since flow control is often essential, measuring the flow of liquids and gasses is a critical need for many industrial applications – and there are many different types of flow meters that can be utilized depending on the nature of the application.

- Mass flow rate = Volume flow rate \* density

$$\dot{M} = Q * \rho$$

$$Q = V * A$$

V : Flow velocity

A : Cross Section Area

SCCM: Standard cubic CM / M

Flow Rate (Q)

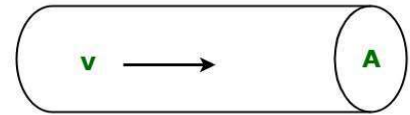

$$Q = A \times v$$

- Q ( m<sup>3</sup> / s ) , ( ft<sup>3</sup> / s ) , ( GPM ) , ( SCCM )
- $\dot{M}$  ( Kg / s )
- $\rho$  ( Kg / m<sup>3</sup> )

## flow Measurements

### Obstructive

- Positive displacement (Oval Gear)
- Mechanical (Turbine)
- Vortex
- Rotameter
- Differential Pressure

### Non Obstructive

- Electromagnetic
- Ultrasonic
- Coriolis

#### Primary Element

- Orifice Plate
- Flow Nozzle
- Venturi Tube
- Pitot Tube
- Laminar Flow element
- Wedge Element

#### Secondary Element

- Differential Capacitance
- Strain Gauge

#### Electronic Hosing

## ① Positive displacement (Oval Gear)

- There are two oval gears inside the meter, the flow of the fluid causing the gear rotation every revolution called (Pocket).
  - Counting the pocket frequency gives a measurements of the volumetric flow rate.
  - A sensor detects the rotation of the gears to determine the volume flow rate of liquid.
  - Rotational velocity is directly proportional to volume flow rate. ( $Q = VA$ )
- Designed for use with higher-viscosity fluids.
  - It's suitable for flow measurement for different measuring media (acid, alkali, chemical, petroleum, oil, food industries).
  - The flowmeter can be made of (cast steel, stainless steel 316).
  - The display meter has the functions of displaying cumulative flow, instantaneous flow and zero return.



### Advantages:

- Accurate (0.5%).
- Simple to install.
- Handling high pressure.
- Working temperature = 160 °c

### Disadvantages:

- Unsuitable for steam.
- Unsuitable for high & low Temperature applications.
- Unsuitable for low viscosity fluids including water.
- Accuracy affected by bubbles present in fluids.

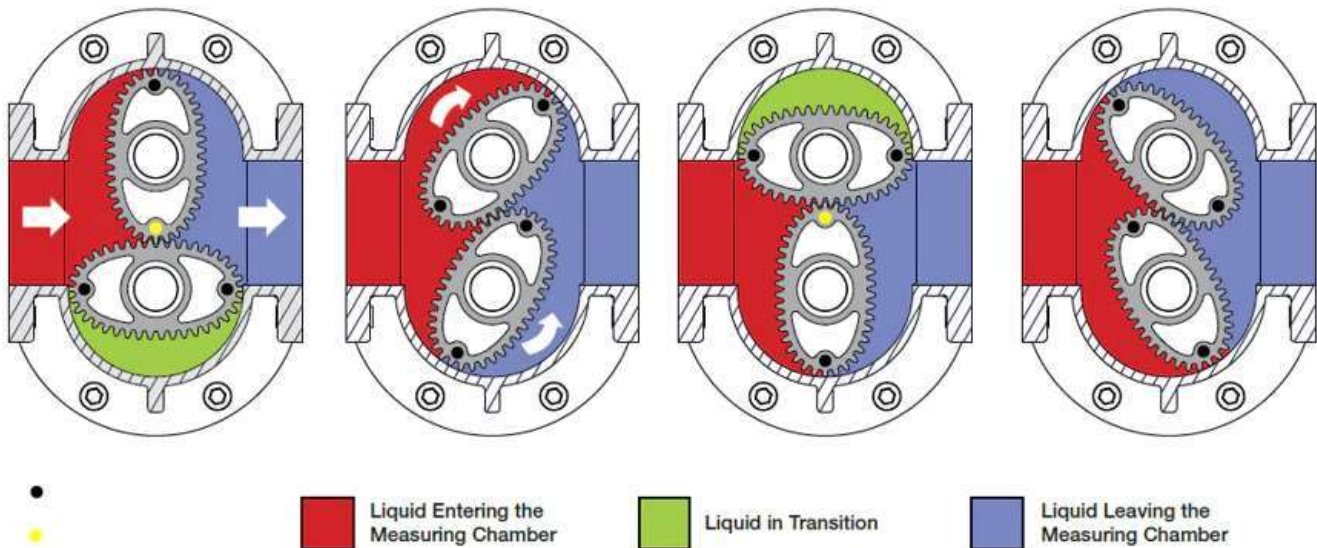

## ② Mechanical (Turbine):

- A Turbine Flow Meter is inserted in a pipe directly in the flow path.
- The mechanical part of the Turbine Flow Meter has a turbine rotor placed in the path of a flowing stream.
- The only moving part of the Turbine Meter is the mechanical rotor.
- The rotational speed of the rotor depends upon the flow velocity.
- The rotor blades are usually made of stainless steel.
- As the rotor spins, the passage of each rotor blade past a pickup point will generate an electrical pulse.
- The electrical pulses are created in different ways depending upon the rotor blades themselves and the pickup unit characteristics.

- the turbine rotor will turn at a different speed depending upon the fluid flow velocity.
- Fluid Velocity is a measurement of the distance a particle of a substance traveled per unit of time. Typical velocity units are feet per second or meters per second.
- Fluid Velocity plays a very important role in the operation of a Turbine Flow Meter, but in most applications, a Turbine Flow Meter is used to measure Volumetric Flowrate.
- Volumetric Flowrate indicates the volume of fluid that passes a point in a unit period of time.
- If you could count the number of gallons of liquid flowing past a certain point in one minute, you would be able to state the Volumetric Flowrate.
- Volumetric Flowrate is expressed in units such as:
  - gallons per minute (GPM)
  - cubic meters per second ( $m^3/s$ )
  - cubic feet per second ( $ft^3/s$ )

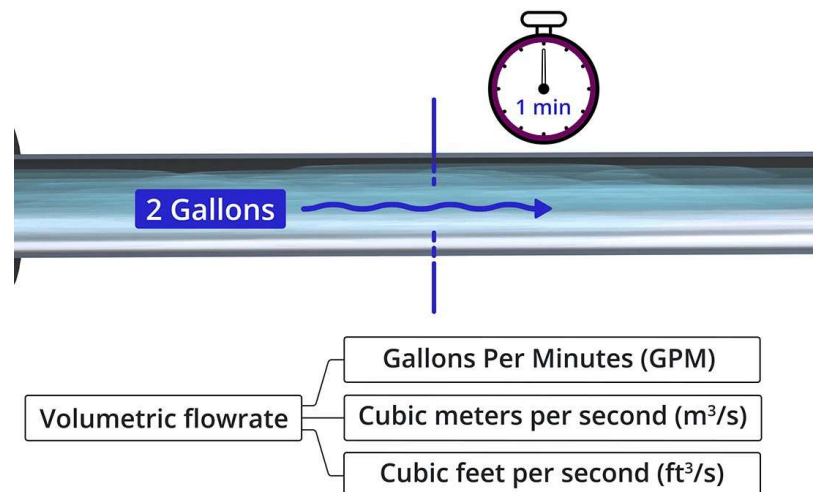
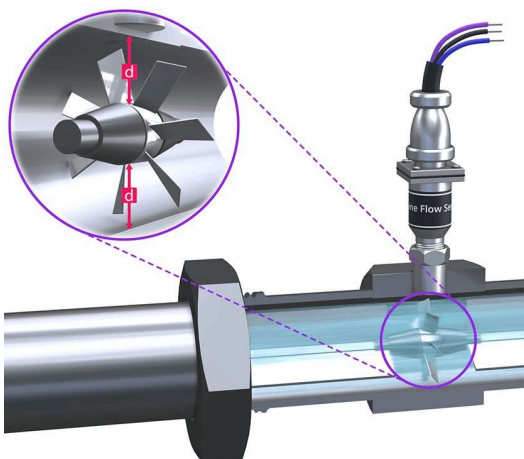
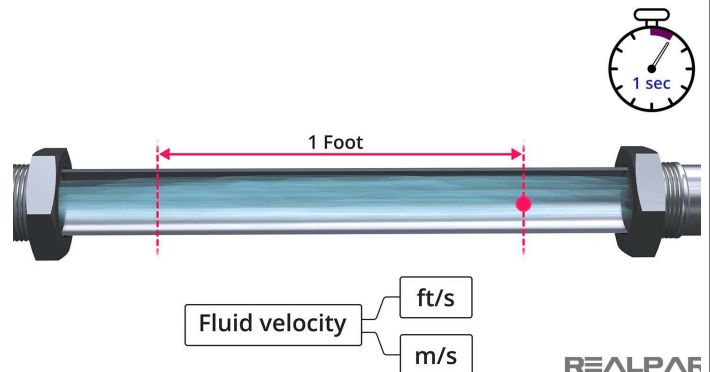
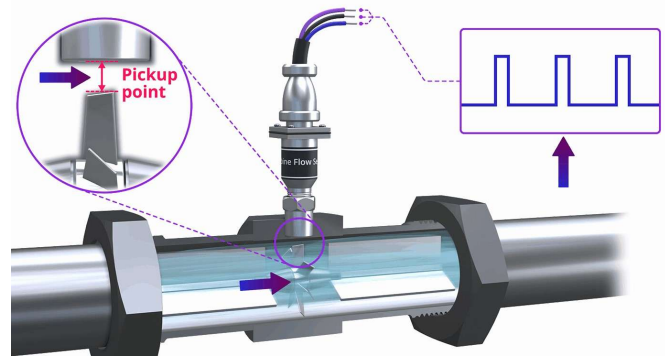

You will find Turbine Flow Meters in oil and gas including fracking, water and wastewater, chemical, power, food and beverage, aerospace, pharmaceutical, and pulp and paper.

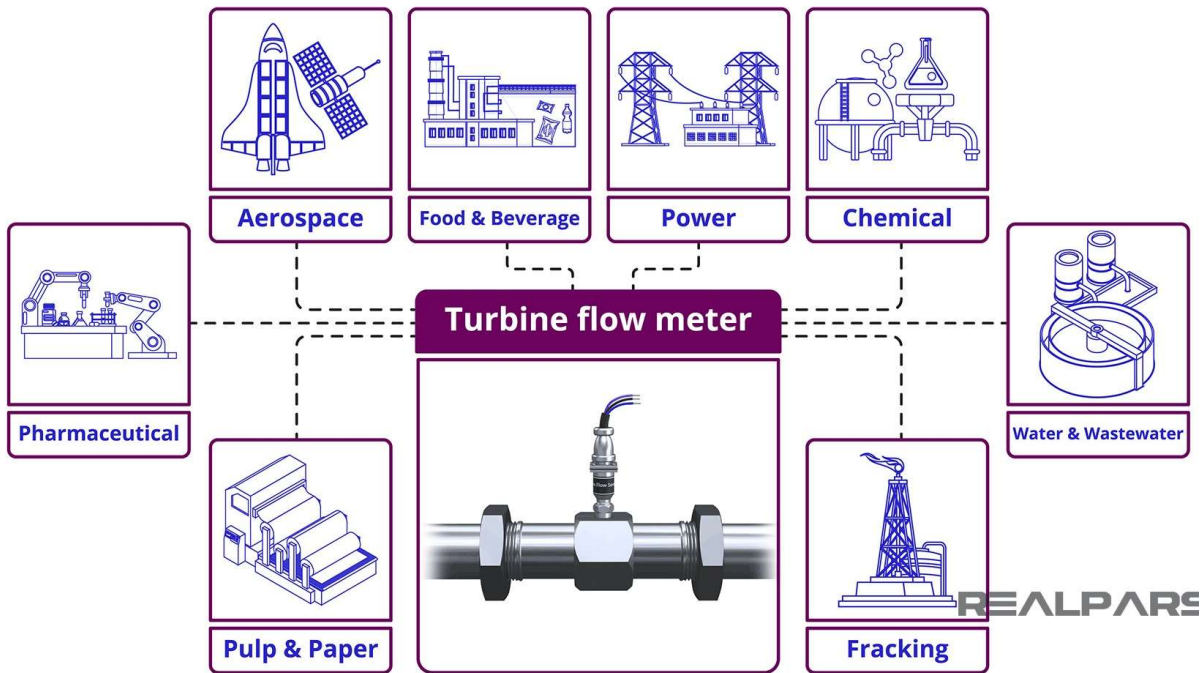

**Advantages:**

- Accurate (0.5%) can be improved 0.2 %.
- The material of its body is stainless steel.
- Suitable for { gases , liquids }.

**Disadvantages:**

- Not suitable with too high viscosity.
- Need frequent calibration.
- Deal only with clean liquids.
- Max temperature = 120 °c

**Installation of a turbine flow meter:**

Typical installation requires 10 pipe diameters upstream of straight pipe and 5 pipe diameters downstream.

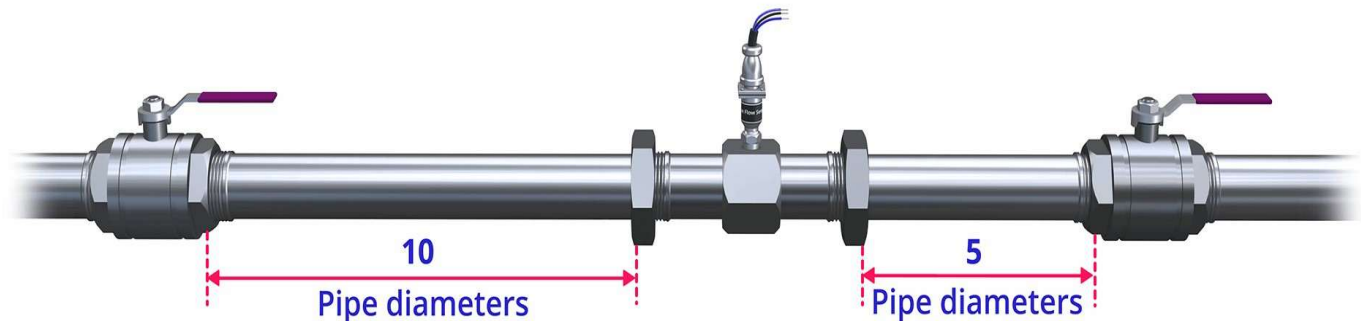

### ③ Vortex:

Vortex measures vortices, essentially, a sensor tab will bend and flex from side to side as the vortex passes. The bend and flex action will then produce an output frequency that is proportional to volumetric flow.

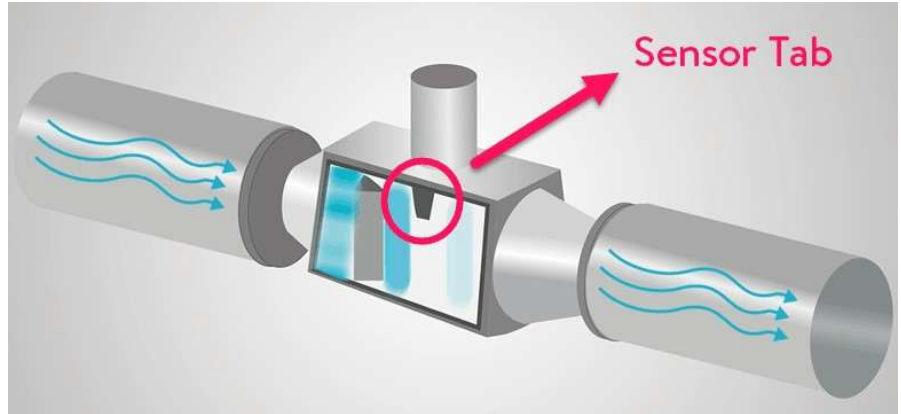
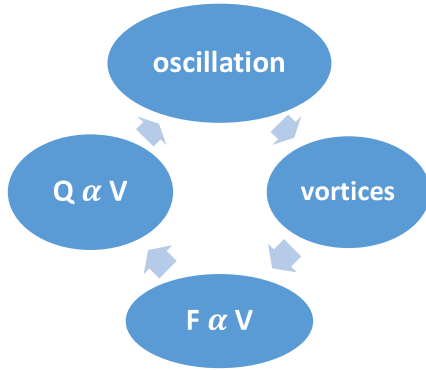

#### Advantages:

- Suitable for low viscosity liquids.
- Suitable for { gases , steam }.
- Low pressure loss.
- High accuracy.
- High stability.
- Wide measurement range.
- Reliable and advanced instruments.

#### Disadvantages:

- It has poor anti-vibration performance.
- Can't measure dirty media.

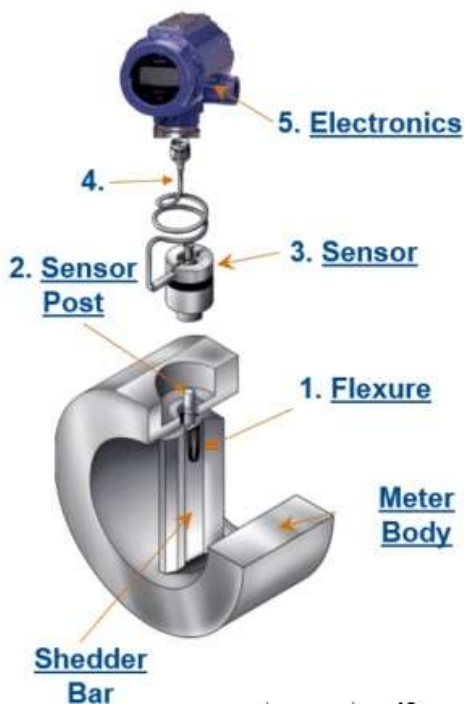

#### ④ Rotameter:

- A rotameter is a device that measures the flow of fluid volume per unit of time in a closed tube.
- There are several types of rotameter applications, including chemical injection/dosing and tank blanketing.
- A rotameter is a gauge for measuring fluid flow using a graduated glass tube with an enclosed free float.
- Also known as variable area flow meters, rotameters are used to measure liquid or gas volumetric flow rates as they pass through the tapered tube of the rotameter.
- The flow of the liquid or gas raises the meter's float, increasing the area through which the media may pass. The larger the amount of flow, the higher the float is raised.
- A rotameter can be used for purge applications to keep process lines clear. In simple flow measurement, an alarm or an electrical output makes it possible to check flow conditions and control them continuously.

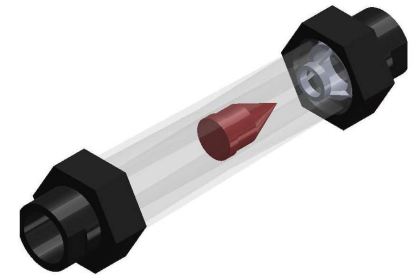

#### ➤ How Rotameters Work?

- Fluid enters the tube from the bottom and escapes through the top. This fluid is the one whose flow is measured. The float will rest at the bottom of the tube when there is no flow in the instrument. In such a situation, the total diameter of the float is nearly equal to the inside diameter of the glass tube.
- The flow area of the annular opening increases when the fluid enters the tube, thus making the float move upwards. It moves upwards until the lifting strength produced from the difference in pressure across its upper and lower surfaces begins to equal the float weight.
- The lifting force and pressure difference will temporarily increase due to the flow rate increase in the rotameter. Afterward, the float travels to the top and increases the area in the annular opening.
- Due to this, the lifting force will decrease, and the force of the fluid will become the same as the float weight. The difference in pressure remains the same by changing the area of the annular opening in relation to the flow rate. The scale marked on the glass tube indicates the flow rate.
- When using rotameters, calibration must be undertaken for a given gas or fluid at a given set of conditions. Normally, the conditions are written on the sides of the flow meter along with its range of flow and the units of measurement. In using rotameters, one is always advised to correct the flow tube readings according to any changes in flow conditions. Usually, manufacturers detail the required corrections for the meters, but this is not always the case.

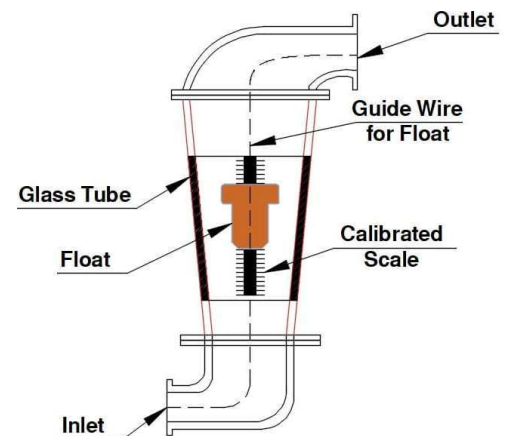

#### Advantages:

- Measuring very low to high flow rate.
- No external power.
- Simple.
- Low cost.
- Low pressure drop.
- Repeatability.
- Optional flow switches, alarms.

#### Disadvantages:

- Must be mounted vertically.
- Low accurate with high flow rate.

## ⑤ Differential Pressure:

Primary element	Secondary element (Transducer)	Electronic housing (Transmitter)
1- Orifice plate	Differential capacitance	
2- Flow nozzle	Strain gauge	
3- Venture tube		
4- Pitot tube		
5- Laminar flow element		
6- Wedge element		

- A common method of flow measurement is done by using a Differential Pressure Transmitter (also called a DP Transmitter). The Differential Pressure Transmitter often referred to as a Delta P transmitter.
- When plotted on a graph, the relationship between flow rate (Q) and differential pressure ( $\Delta P$ ) is quadratic, like one-half of a parabola. Differential pressure developed by a venturi, orifice plate, pitot tube, or any other acceleration-based flow element is proportional to the square of the flow rate.

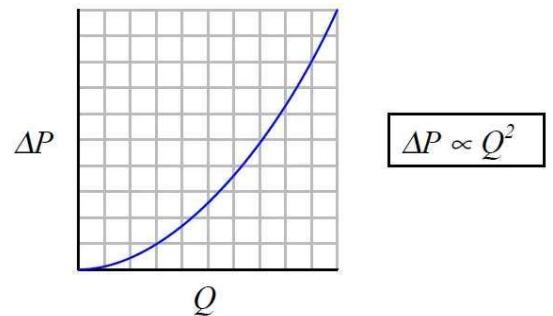

- Unfortunately, the Differential pressure across the orifice is not proportional to the flow rate but is actually proportional to the square of the flow rate. That's why in applications like this, we need a Square Root Extractor. Sometimes this square root function is built into the transmitter and sometimes a Square Root Extractor is a separate signal conditioning instrument connected to the output of the transmitter.

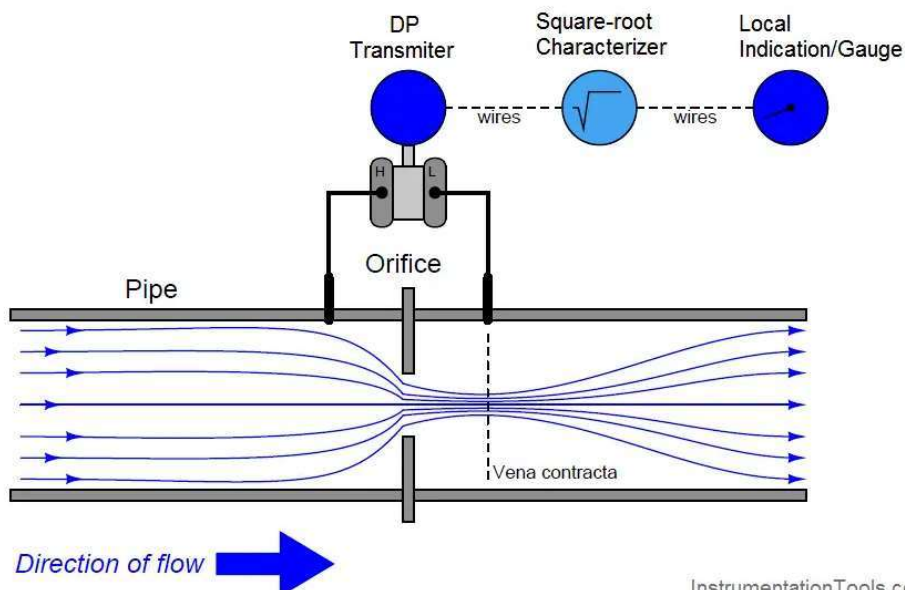

- The square-root function placed immediately after the flow element's "square" function – the result is an output signal that tracks linearly with flow rate (Q).

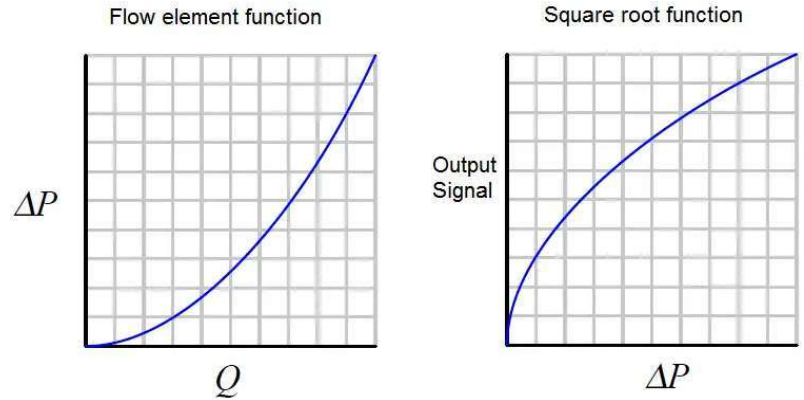

- If we are using square root extraction function which is available inside the transmitter (software configuration).
- This way, no external relay device is necessary to characterize the DP transmitter's signal into a flow rate signal.

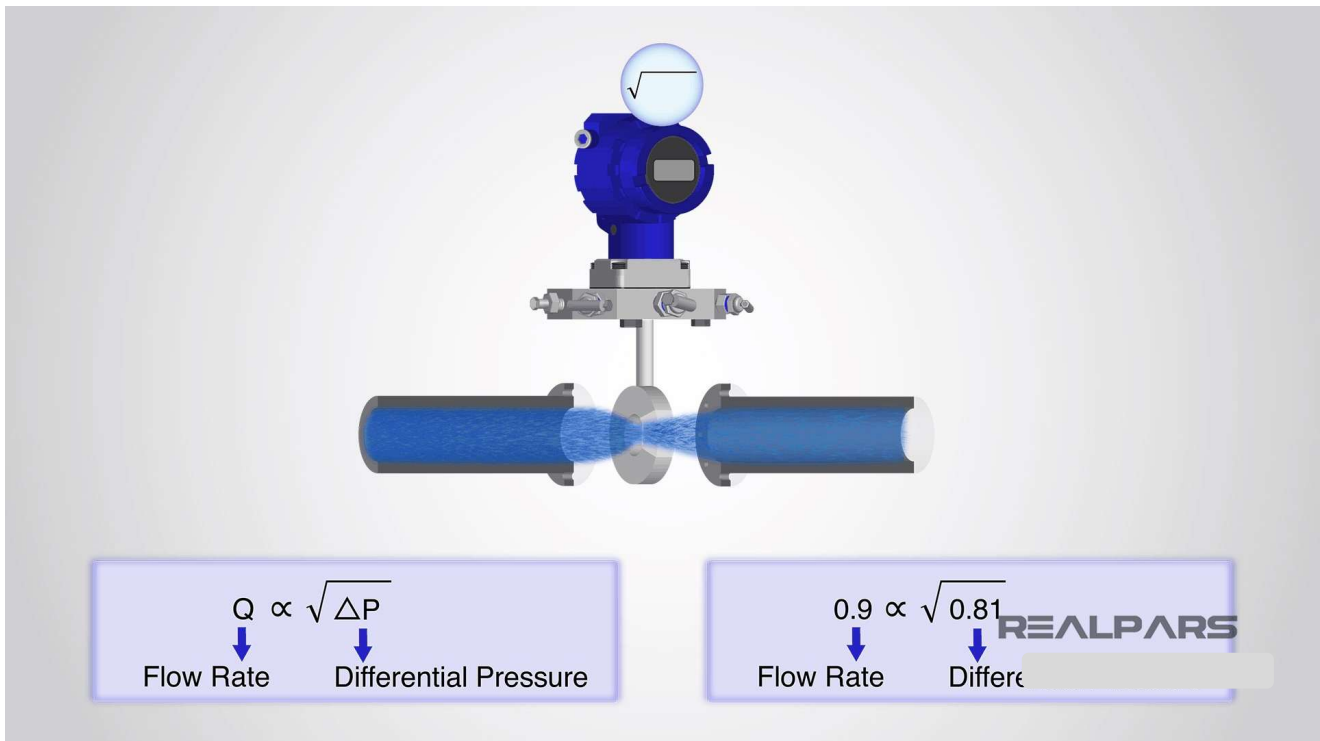
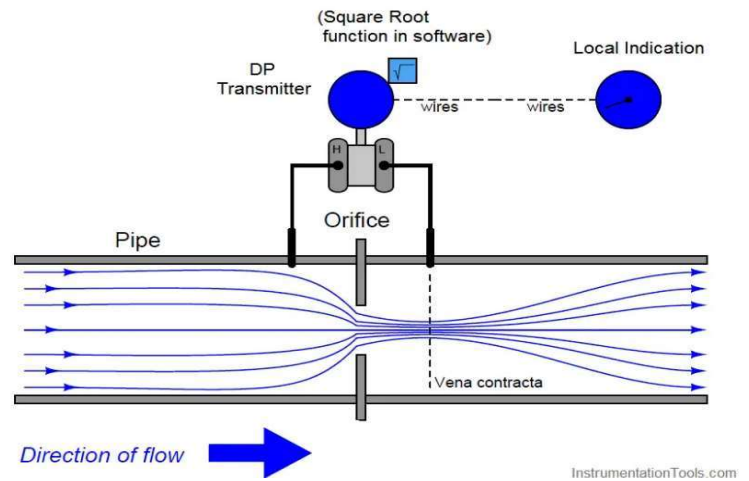

## **Orifice plate :**

- An Orifice Meter is basically a type of flow meter used to measure the rate of flow of Liquid or Gas, especially Steam, using the Differential Pressure Measurement principle.
- It is mainly used for robust applications as it is known for its durability and is very economical.
- As the name implies, it consists of an Orifice Plate which is the basic element of the instrument. When this Orifice Plate is placed in a line, a differential pressure is developed across the Orifice Plate.
- This pressure drop is linear and is in direct proportion to the flow rate of the liquid or gas.
- The Orifice plates in the Orifice meter, in general, are made up of stainless steel of varying grades.

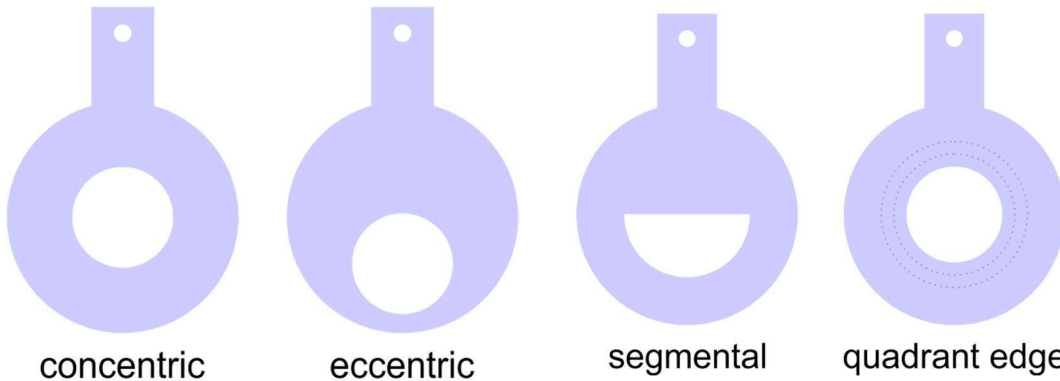

- Orifice meters are built in different forms depending upon the application-specific requirement, The shape, size, and location of holes on the Orifice Plate describe the Orifice Meter Specifications as per the following:
- ❖ Concentric Orifice Plate: used with pure liquid like gases.
  - ❖ Eccentric Orifice Plate: used for viscous flow.
  - ❖ Segment Orifice Plate: used for viscous flow.
  - ❖ Quadrant Edge Orifice Plate: used for crude oil, high-viscosity syrups or slurries.

### Advantages:

- very cheap.
- Less space is required to Install.
- Operational response can be designed with perfection.
- Installation direction possibilities:  
Vertical / Horizontal / Inclined.

### Disadvantages:

- At higher fluid velocity causes turbulences.
- Solids in fluids causes damages.
- Low life time.

## **Flow nozzle:**

The main parts of flow nozzle arrangement used to measure flow rate are as follows:

1. A flow nozzle which is held between flanges of pipe carrying the fluid whose flow rate is being measured. The flow nozzle's area is minimum at its throat.
2. Openings are provided at two places 1 and 2 for attaching a differential pressure sensor (u-tube manometer, differential pressure gauge etc.,) as show in the diagram.

### ➤ Operation of Flow Nozzle

1. The fluid whose flow rate is to be measured enters the nozzle smoothly to the section called throat where the area is minimum.
2. Before entering the nozzle, the fluid pressure in the pipe is  $p_1$ . As the fluid enters the nozzle, the fluid converges and due to this its pressure keeps on reducing until it reaches the minimum cross section area called throat.

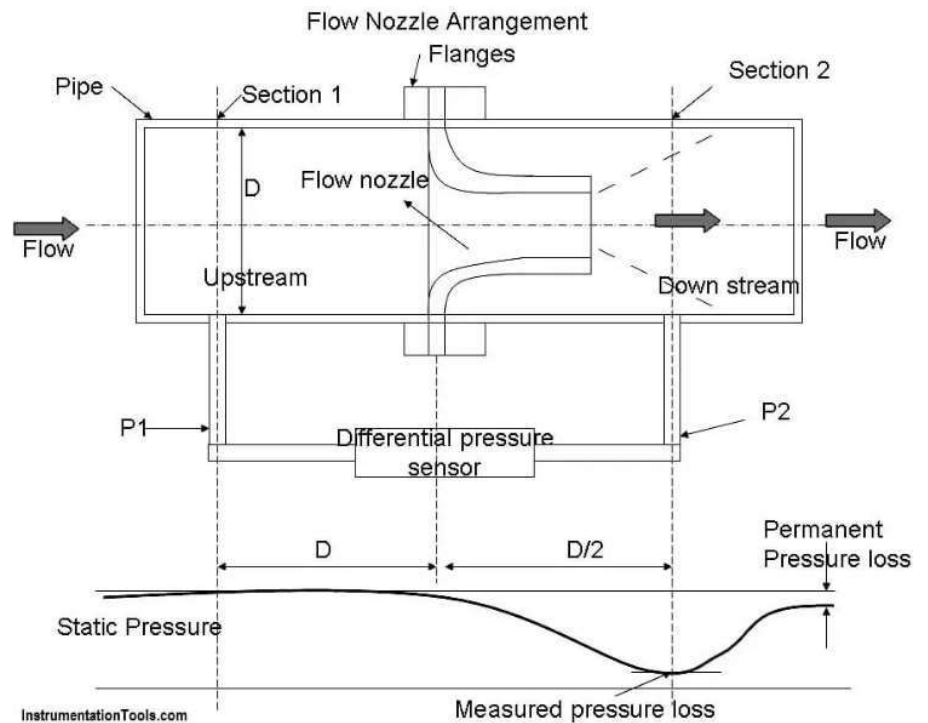

This minimum pressure  $p_2$  at the throat of the nozzle is maintained in the fluid for a small length after being discharged in the downstream also.

3. The differential pressure sensor attached between points 1 and 2 records the pressure difference ( $p_1 - p_2$ ) between these two points which becomes an indication of the flow rate of the fluid through the pipe when calibrated.

### Advantages:

- Installation is easy and is cheaper when compared to venturi meter.
- It is very compact
- Has high coefficient of discharge.

### Disadvantages:

- Pressure recovery is low
- Maintenance is high
- Installation is difficult when compared to orifice flow meter.

## **Venture tube:**

- The fluid whose flow rate is to be measured enters the entry section of the venturi meter with a pressure  $P_1$ .
- As the fluid from the entry section of venturi meter flows into the converging section, its pressure keeps on reducing and attains a minimum value  $P_2$  when it enters the throat. That is, in the throat, the fluid pressure  $P_2$  will be minimal.

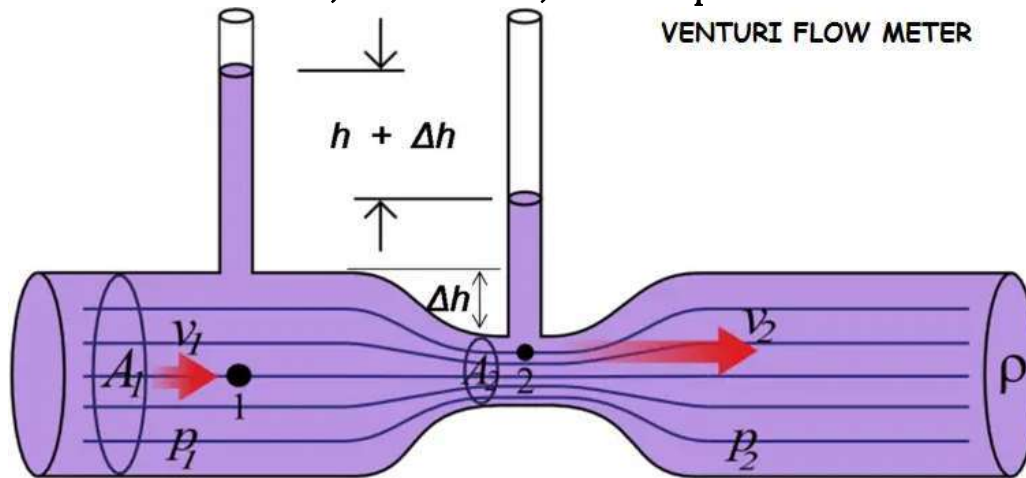

- The differential pressure sensor attached between the entry and throat section of the venturi meter records the pressure difference ( $P_1 - P_2$ ) which becomes an indication of the flow rate of the fluid through the pipe when calibrated.
- The diverging section has been provided to enable the fluid to regain its pressure and hence its kinetic energy. The lower the angle of the diverging section, the greater the recovery.

### **Advantages:**

- Fewer chances of getting clogged with sediments
- The coefficient of discharge is high.
- Its behavior can be predicted perfectly.
- Can be installed vertically, horizontally, or inclined.
- Low-pressure drop (around 10% of  $\Delta p$ )
- Lower sensitivity to installation effects than orifice plates
- Less susceptibility to damage
- More suitable for gas flows with entrained liquid.

### **Disadvantages:**

- large in size.
- Expensive initial cost, installation, and maintenance.
- Greater cost to manufacture
- Less experimental data than orifice plates

## ✚ how to carry out piping delta p flow meter?

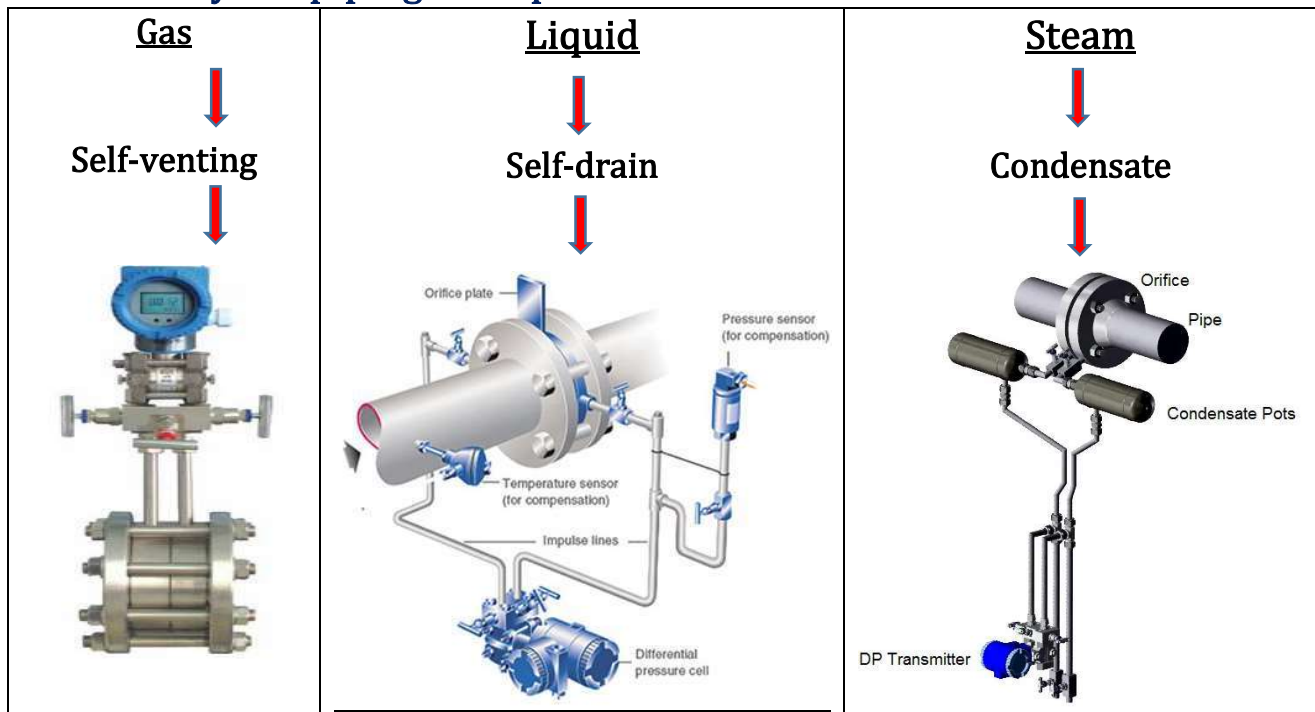

## ✚ Calibration Procedure:

### ❖ Removing the Transmitter from Service

The transmitter must be removed from service before any checks or calibration can be performed. Let's go through the following steps:

- Close the Low-Pressure Block Valve
- Open the Equalizing Valve
- Close the High-Pressure Block Valve

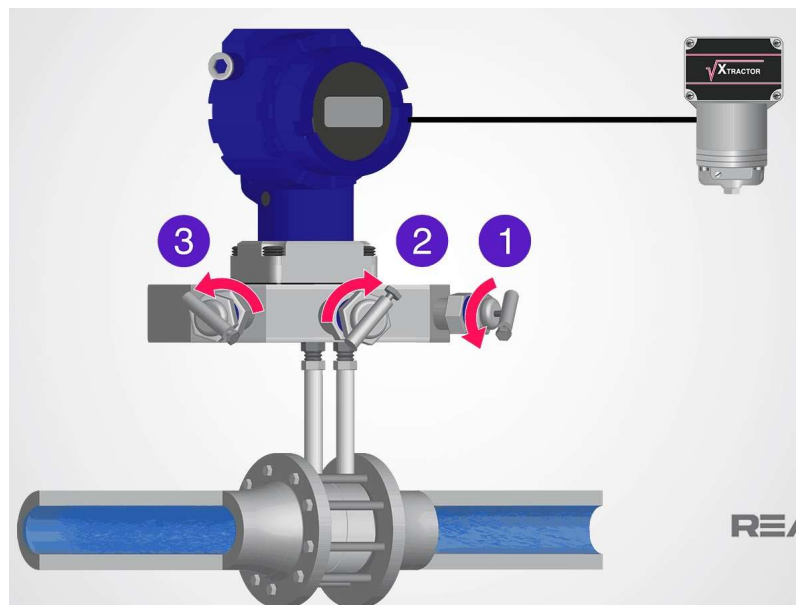

## Calibration Chart

We are going to ignore the square root extractor for now as we will be looking at the output current from the flow transmitter.

The first thing we need is a calibration chart or table. A table like this or similar is usually kept on file at your place of work.

This table is important from a calibration perspective as it indicates what we need to apply to the transmitter, and what the expected current output will be.

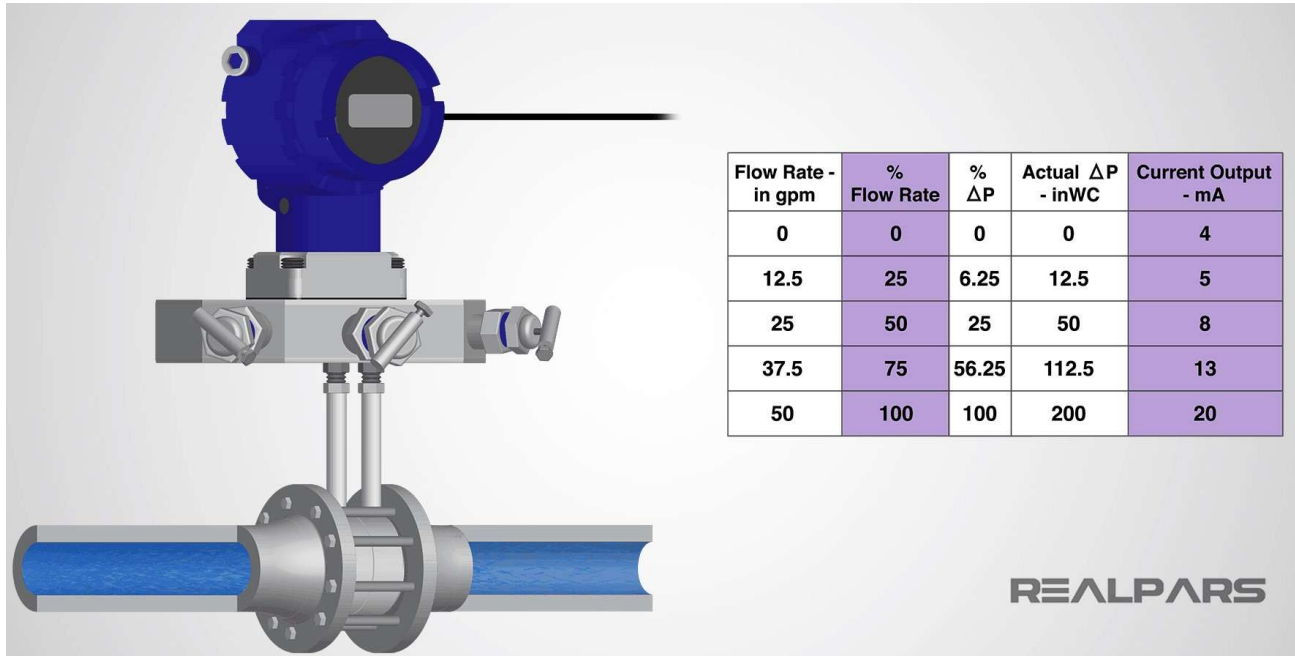

### Calibration Setup

Here's the calibration setup. The scissor-type hand pump with a digital pressure readout is connected to the high-pressure side of the transmitter.

There are several different types of pressure sources used in the industry. Note that the low-pressure side of the transmitter is vented to the atmosphere.

A digital multimeter set to measure current is connected in series with the transmitter and the 24-volt power supply.

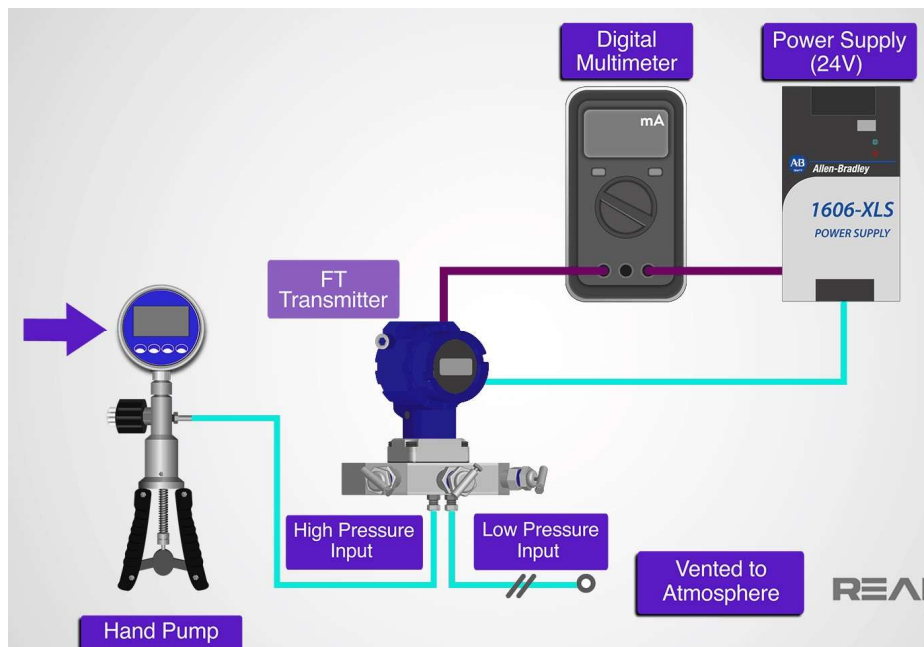

From the table, we can see that if we set the hand pump input pressure to 50 inches of Water Column, our multimeter should read 8 milliamps.

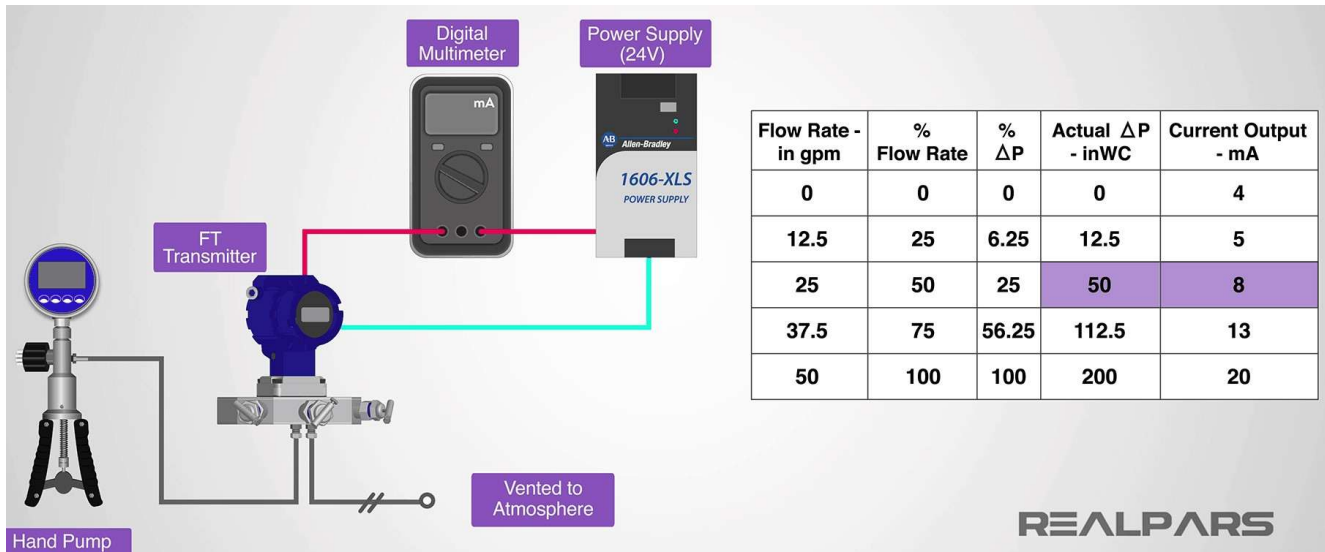

OK, now we've seen how the calibration table will work for us. We've got the transmitter all set up, let's do some testing.

First of all, we're going to check to see if the transmitter needs to be adjusted. We begin by applying the desired pressure input values from the calibration table to the high input on the flow transmitter and record the output current measured for each input value.

If the output currents measured are outside of the acceptable ranges as established by your company, then the transmitter must be recalibrated using the Zero/Span adjustments.

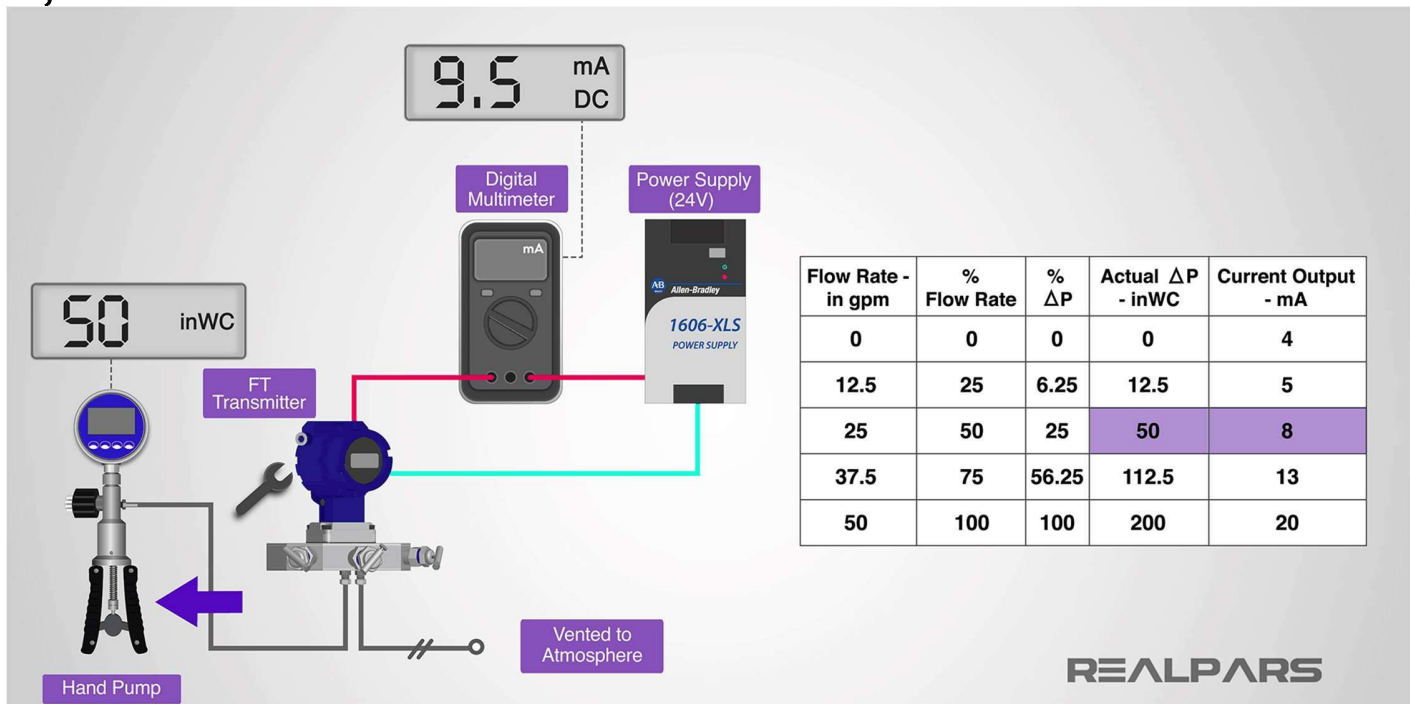

We perform the actual calibration using the Zero/Span adjustments on the transmitter. Apply the 0% input pressure value, which for us is 0 inches Water column, to the transmitter and adjust the Zero until we get an output current of 4 milliamps.

Flow Rate - in gpm	% Flow Rate	% ΔP	Actual ΔP - inWC	Current Output - mA
0	0	0	0	4
12.5	25	6.25	12.5	5
25	50	25	50	8
37.5	75	56.25	112.5	13
50	100	100	200	20

**REALPARS**

Apply the 100% input pressure value, which for us is 200 inches Water Column, to the transmitter and adjust the Span until we get an output current of 20 milliamps. Repeat the steps until adjustments are no longer required.

Flow Rate - in gpm	% Flow Rate	% ΔP	Actual ΔP - inWC	Current Output - mA
0	0	0	0	4
12.5	25	6.25	12.5	5
25	50	25	50	8
37.5	75	56.25	112.5	13
50	100	100	200	20

**REALPARS**

## ✚ Returning the Transmitter to Service

Now that you've recalibrated, it's a good idea to apply all of the values from the calibration table and record the corresponding output current values.

Let's return the transmitter to service now that it's been calibrated.

- Begin with all valves closed
- Open the equalizing valve
- Open the High-Pressure Block Valve (slowly)
- Close the equalizing valve
- Open the Low-Pressure Block Valve

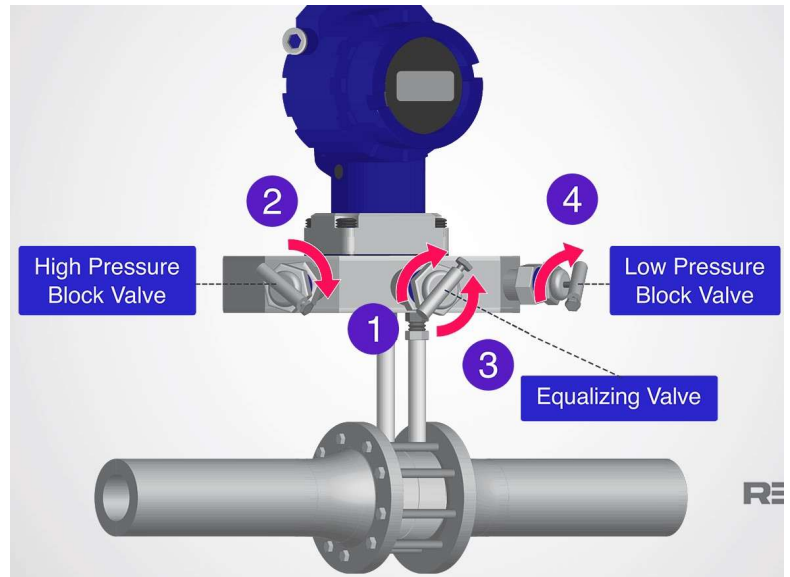

❖ Remember, we ignored the square root extractor when we calibrated the transmitter. Let's connect the square root extractor to the output of the transmitter and see what happens.

We now have a linear and directly proportional relationship between the flow rate and the current output of the square root extractor. Perfect! That's exactly what our [PLC](#) or [DCS](#) needs to see.

The math is a bit complicated, but let's try an example. When we have a 50% flow rate of 25 gallons per minute, the square root extractor output is 12 milliamps, or 50% as well. But, the Flow transmitter output is 8 milliamps or 25%.

How do we convert 8 milliamps to 12 milliamps?

Very simply, the square root extractor will ensure that its output is the square root of its input.

The square root of 25% is 50%! Try the math on a calculator. So, with a Flow Transmitter output current of 8 milliamps, the square root extractor will produce an output current of 12 milliamps

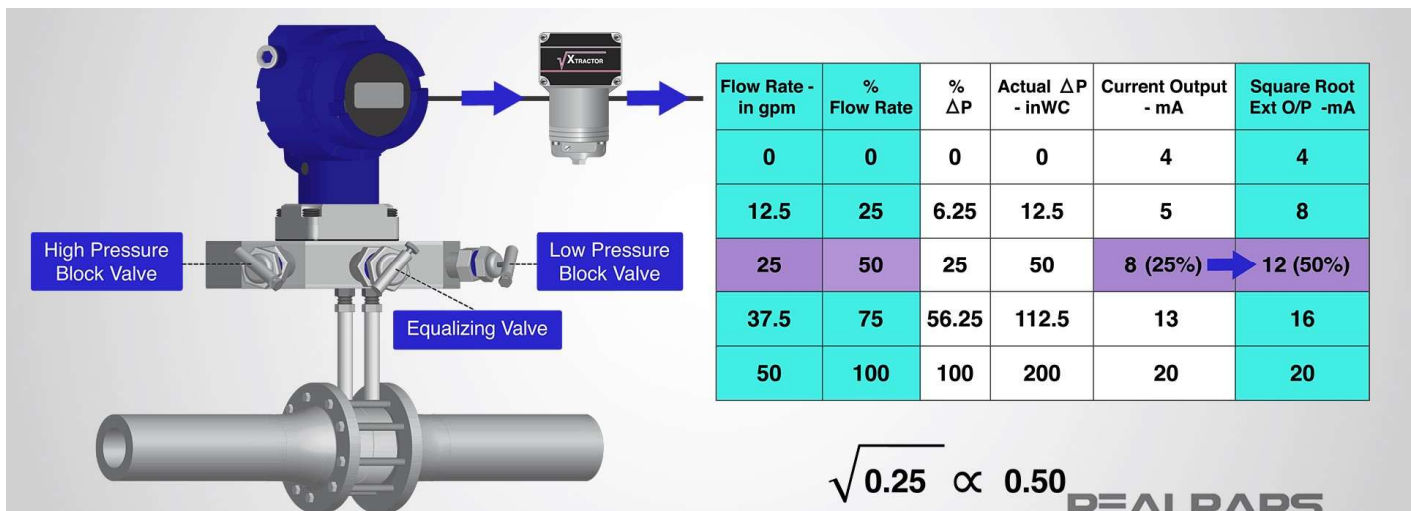

## ⑥ Electromagnetic:

- The measured liquid must be water based or conductive.
- This makes the mag meter a great choice for waste water or process water that is considered fouled or dirty.
- Mag meters are volumetric meters that have no moving parts. This is ideal for those areas where you wouldn't want to be exposed to the measured liquid while working on the meter.
- The way a mag meter works is based on a formula called Faraday's formula. Firstly, again, the liquid must be conductive. A voltage is measured that is dependent on the average velocity of liquid times the strength of the magnetic field times the length of the conductor (this is the distance between the electrodes).
- We don't need to know Faraday's formula to use a mag meter. We don't necessarily even need to know what that formula is, we just know that whomever invented the mag meter used the formula to produce a signal voltage that can be measured by your automation process.

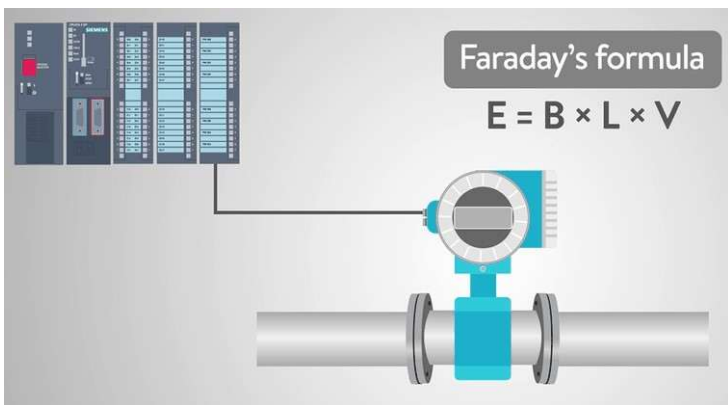
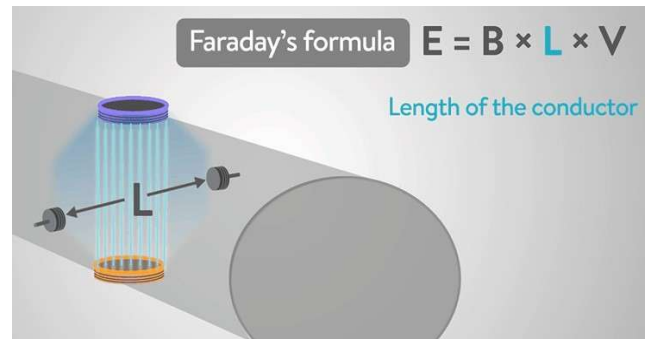
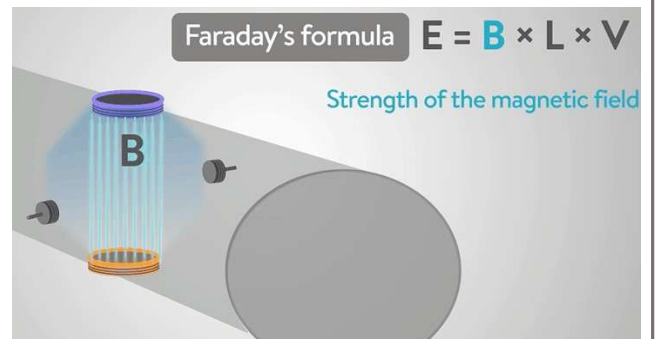
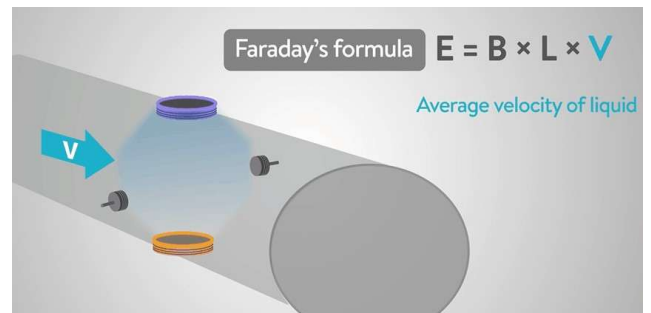
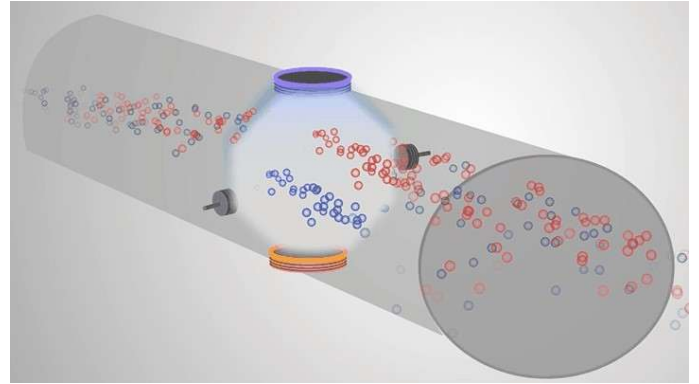

## ⑦ Ultrasonic:

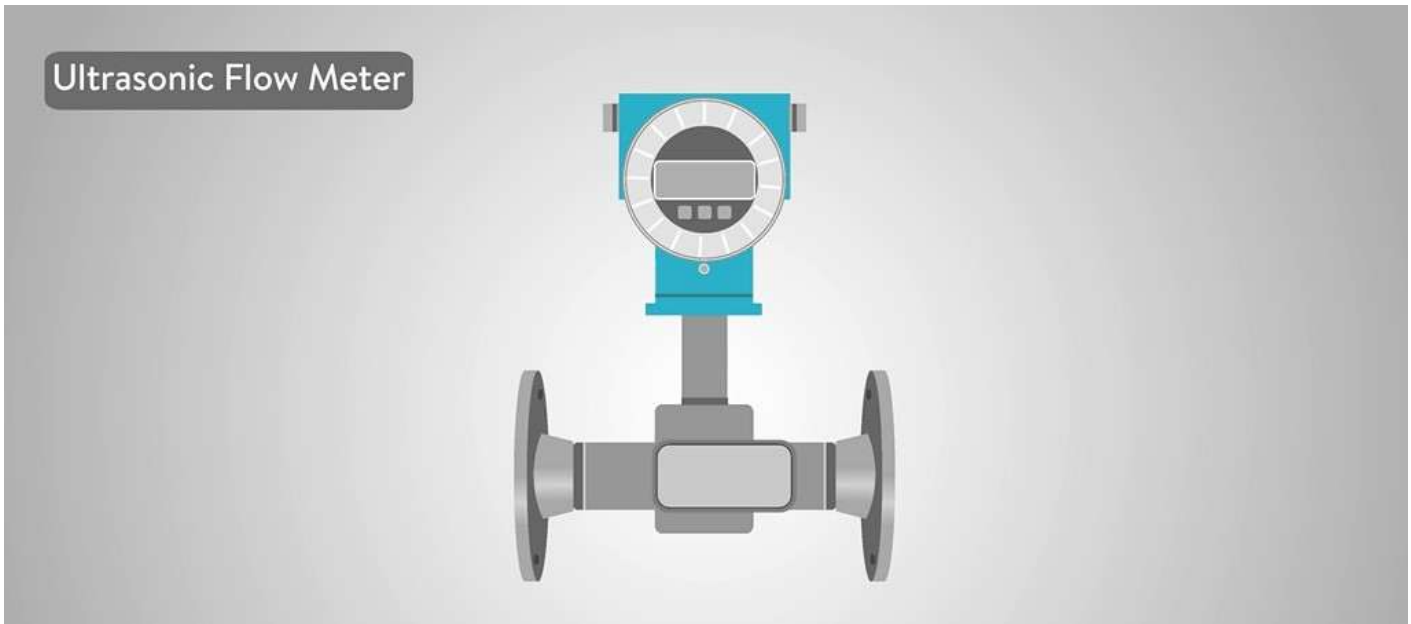

- The principle behind these meters is that an ultrasonic signal is transmitted downstream or in the direction of the flow while another signal is transmitted upstream.
- The delta or differential time is used to calculate the velocity of the liquid.
- That velocity is then used to calculate the volumetric flow through the pipe.

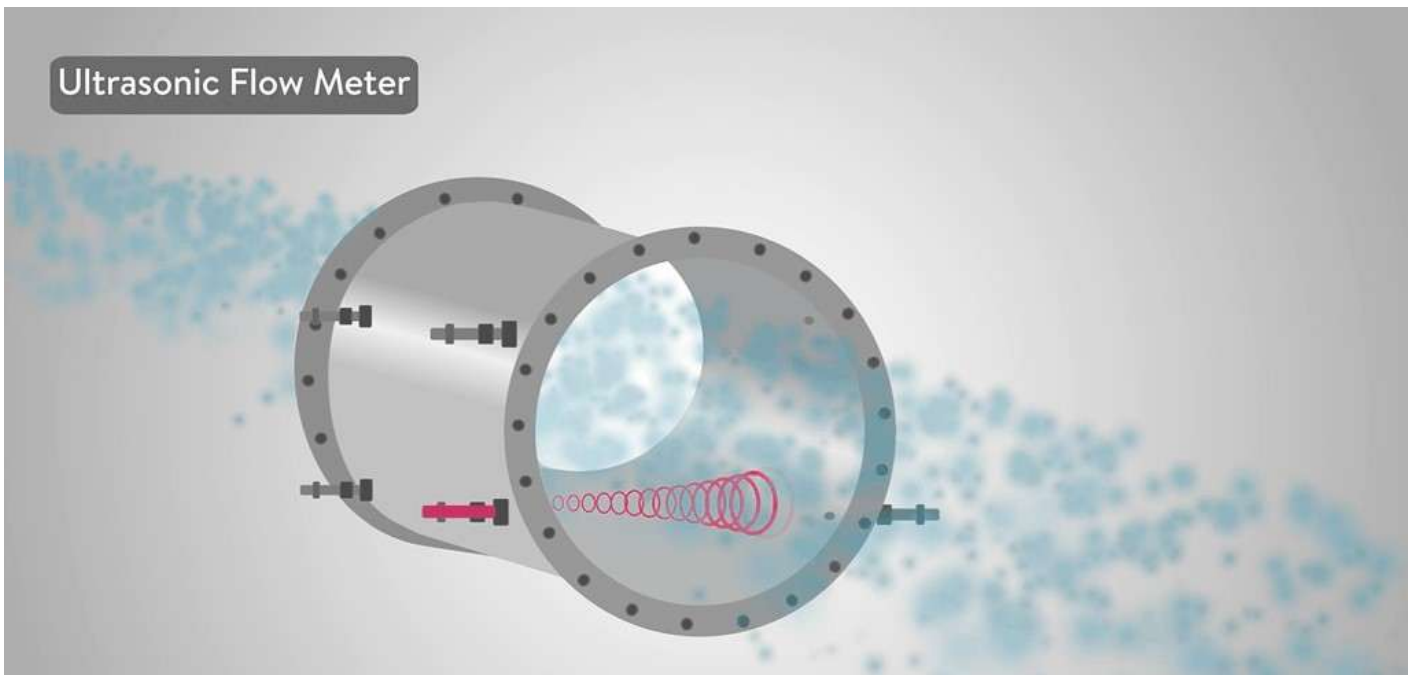

## ⑧ Coriolis:

Each Coriolis flowmeter has one or more measuring tubes which an exciter causes to oscillate artificially. As soon as the fluid starts to flow in the measuring tube, additional twisting is imposed on this oscillation due to the fluid's inertia. Two sensors detect this change of the tube oscillation in time and space as the "phase difference." This difference is a direct measure of the mass flow.

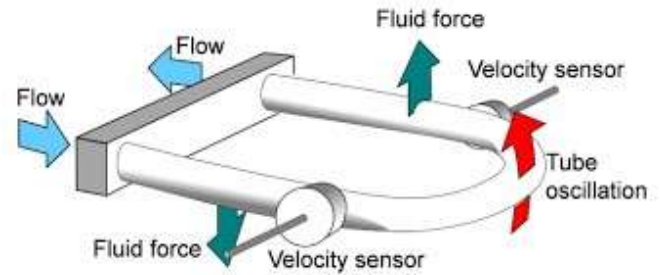

In addition, the fluid density can also be determined from the oscillation frequency of the measuring tubes. The temperature of the measuring tube is also registered to compensate thermal influences. The process temperature derived from this is available as an additional output signal.

### Application Range:

- Chemical: containing chemical reaction system
- Petroleum: moisture content analysis
- Lipids: including vegetable oils, animal fats and other oils
- Textile printing and dyeing
- Fuel: crude oil, heavy oil, coal slurry, lubricant and other fuels
- Food: gas dissolving beverage, health drink and other liquid
- Transportation: pipeline liquid measurement
- High pressure fluid, like slurry flow measurement for oil drilling cementing.

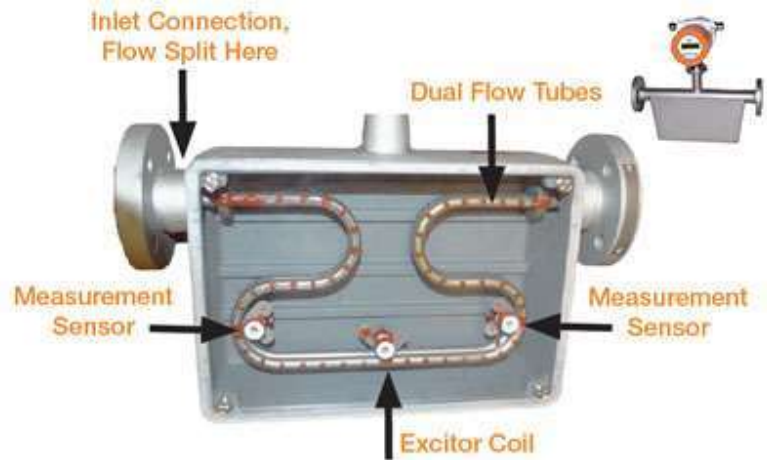

### Advantages:

- Extremely accurate and repeatable
- Not affected by changes in media density
- Good for applications where the media's properties aren't already well known
- Do not require straight piping runs
- Some models can also measure density, temperature, volumetric flow, or viscosity

### Disadvantages:

- higher cost.
- large and heavy.
- Require an inline installation.
- they are not good for dual-phase media.

## ⑦ Control Valves

control valve is simply a variable orifice that is used to regulate the flow of a process fluid according to the requirements of the process.

### Valve types

#### Linear

- Gate
- Globe
- Diaphragm
- Pinch

#### Rotary

- Butterfly
- Plug
- Ball



Globe Valve



Gate Valve



Needle Valve



Ball Valve

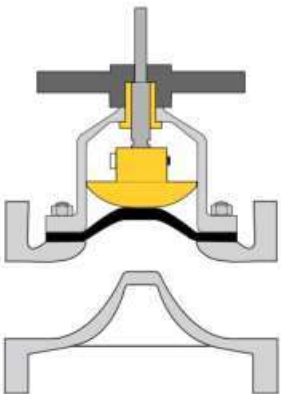

Diaphragm Valve

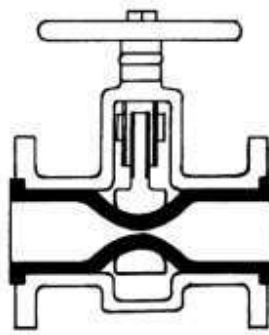

pinch Valve



Butterfly Valve



Plug Valve

# Control Valve Accessories

**Actuator**

- Manual
- Diaphragm
- Electro-Hydraulic
- Motorized
- Piston

**Positioner**

Pneumatic

Electro pneumatic

**Regulator**

Digital valve controller

**Solenoid Valve**

- Direct acting
- Manual reset
- Pilot operated

- With Diaphragm Actuator
- With Piston Actuator
- With Rotary Actuator

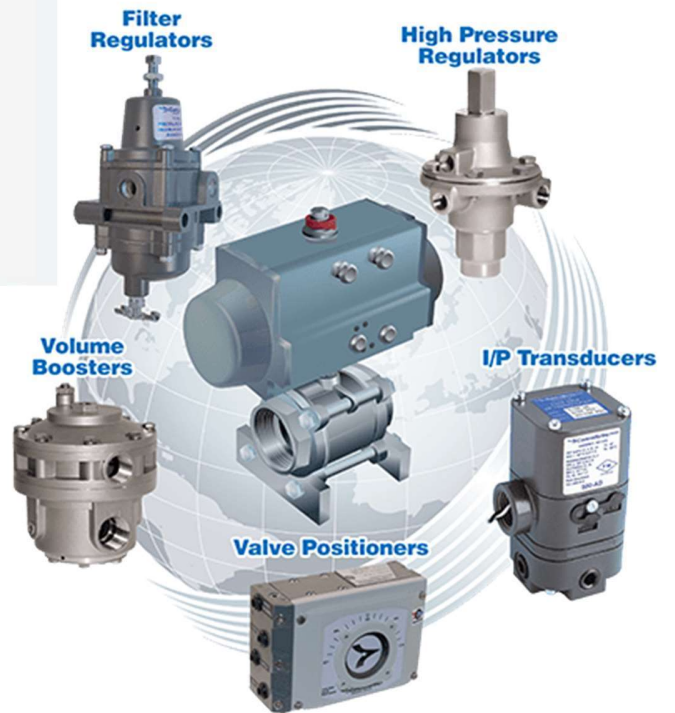
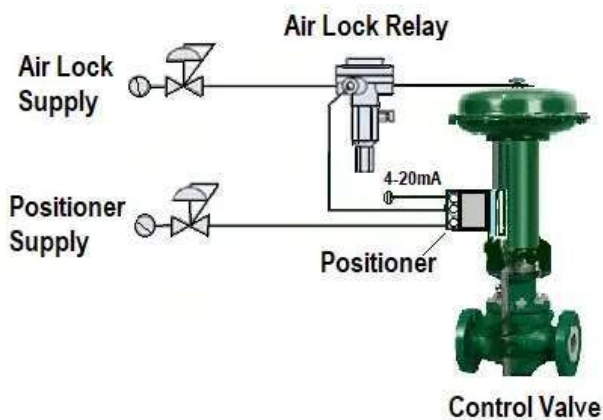
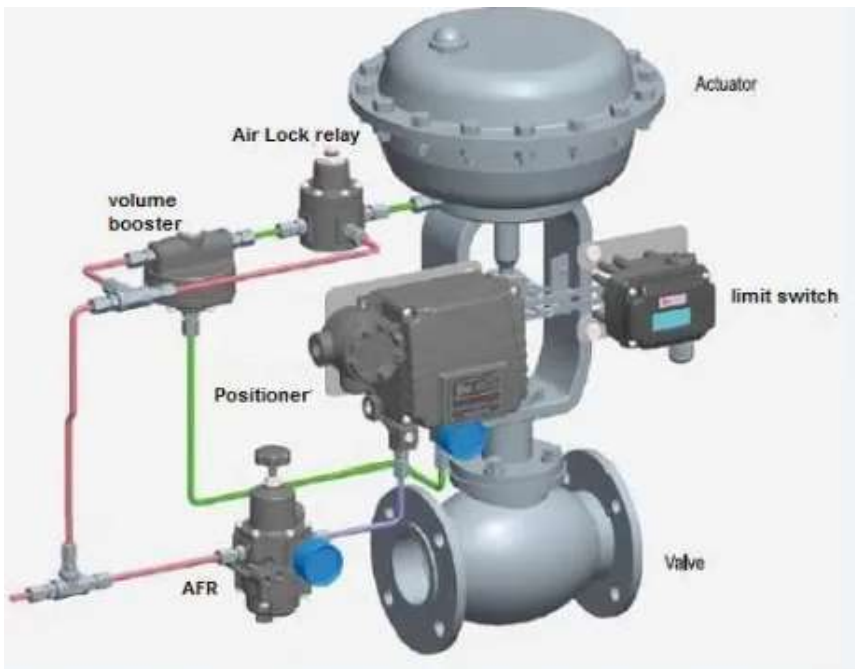

## Manual Actuators :

- Useful where automatic control is not required.
- For manual control of the process during maintenance or shutdown of the automatic system.
- Much less expensive.
- Are available in various sizes for both globe-style valves and rotary-shaft valves.

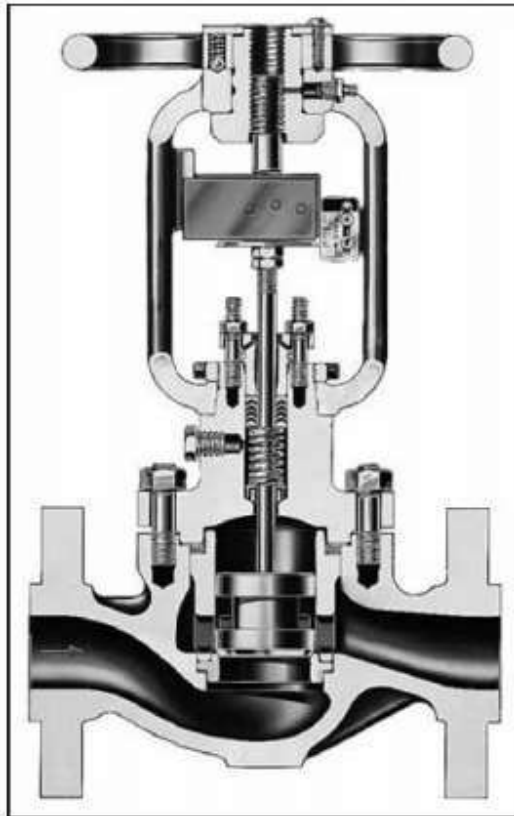

FOR SLIDING-STEM VALVES



FOR ROTARY-SHAFT VALVES

## Diaphragm Actuators:

- Uses input signal from the I/P converter , Positioner or other source like Manual Loader.

- Advantages :

- Dependable

- Simple

- Economical

- Types :

- Direct Acting

- Reverse Acting

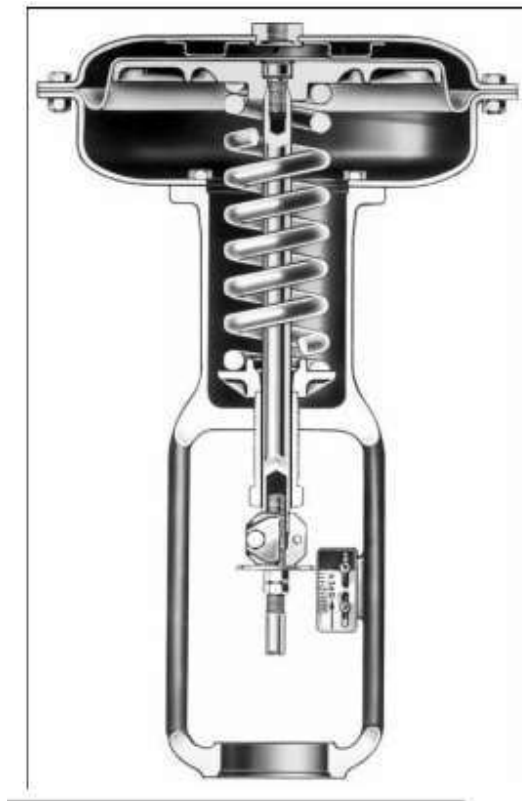

**DIRECT-ACTING**

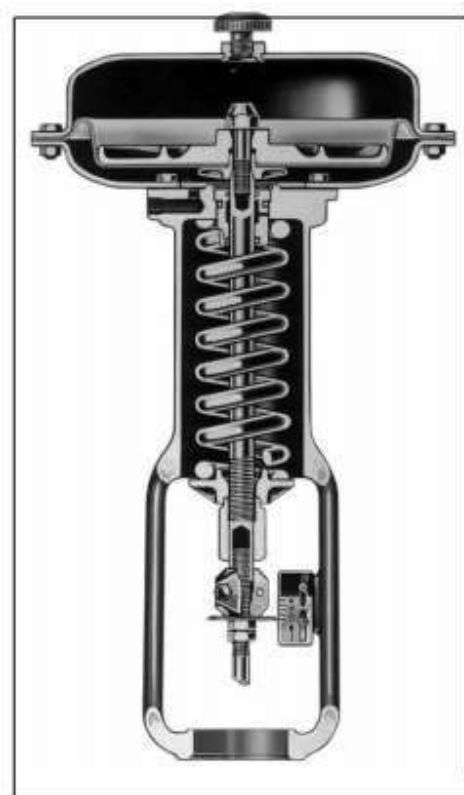

**REVERSE-ACTING**

## Electro-Hydraulic Actuators:

- Disadvantages:
  - More complex.
  - More expensive than pneumatic Actuators.

### Offers Advantages where :

- No air supply source is available.
- Low ambient temperature could freeze the condensed water in pneumatic supply.
- Large stem forces are needed.



## Piston Actuators:

- Uses high pressure plant air up to 150 psig.
- Provides fast stroking speeds.

- Types :

- single acting

- Double acting

- Can produce work in only one direction.
- Uses Built-in spring.

- Limitation :

- Stroke length is limited.

- Applications :

- Fail open or fail closed operation.

- No return spring.
- Able to work in both directions.
- Same two ports are used for supply and exhaust ports.

- Applications :

- mostly used where max. force is required in both directions.

Single Acting Cylinder  
Push Type

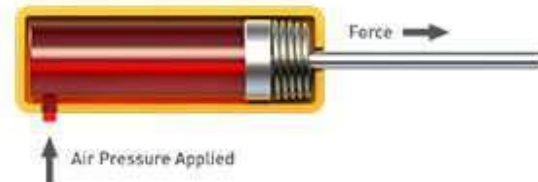
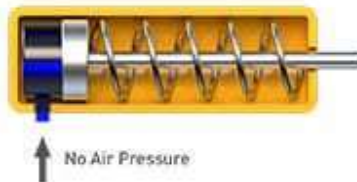

Double Acting Cylinder  
Position 1

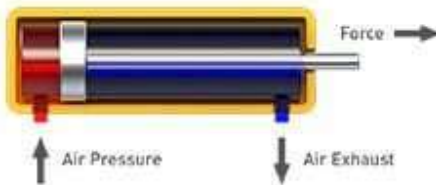

Position 2

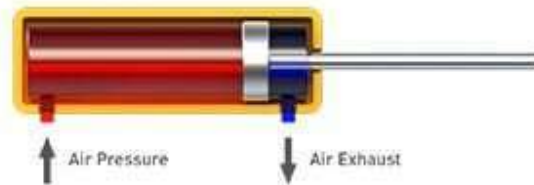

Position 3

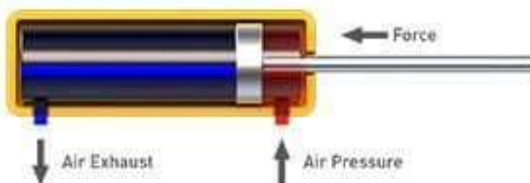

Position 4

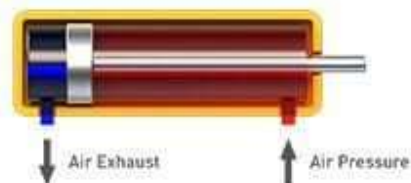

## Pneumatic Positioners :

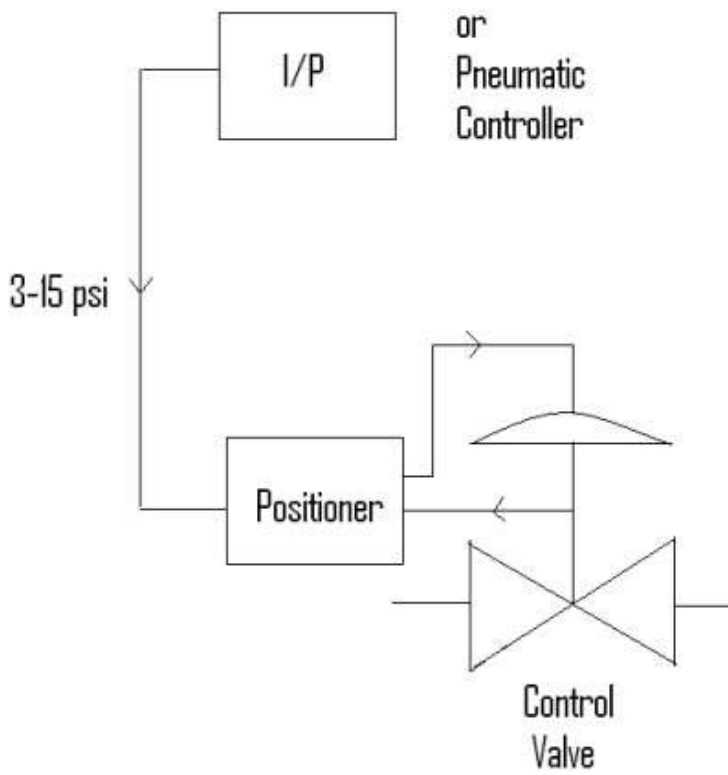

## Electro pneumatic Positioner:

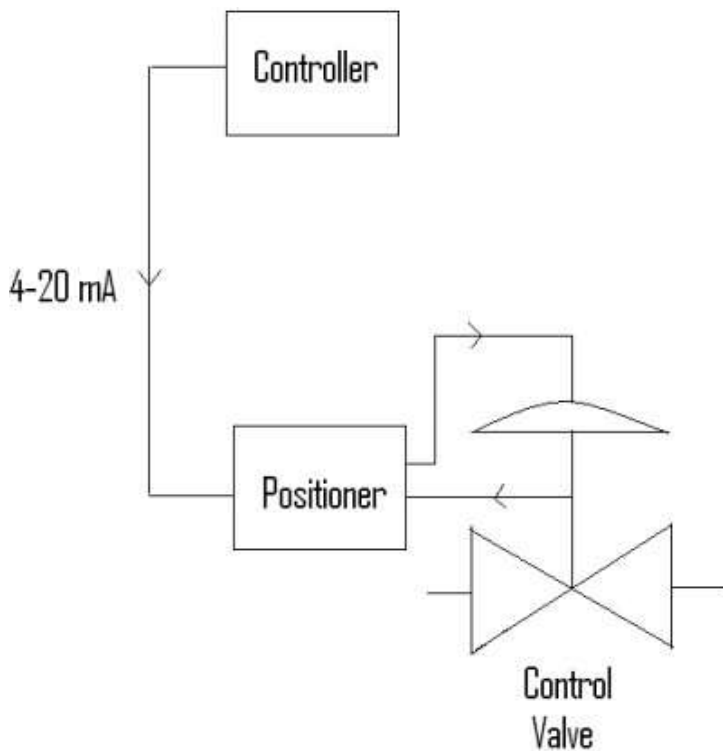

## Digital Valve controllers :

- Communicating (HART, Field-Bus) , Microprocessor based current-to-pneumatic instruments.
  - **Features :**
    - Easy access to information which is critical to process operation.
    - Avoids high cost of running separate power and signal wiring.



Digital valve controller mounted on Diaphragm Actuator



Digital valve controller mounted on Piston Actuator



Digital valve controller with Rotary Actuator

## Air Filter Regulator:

A pressure regulator is an adjustable valve that is designed to automatically control the pressure downstream of the regulator.

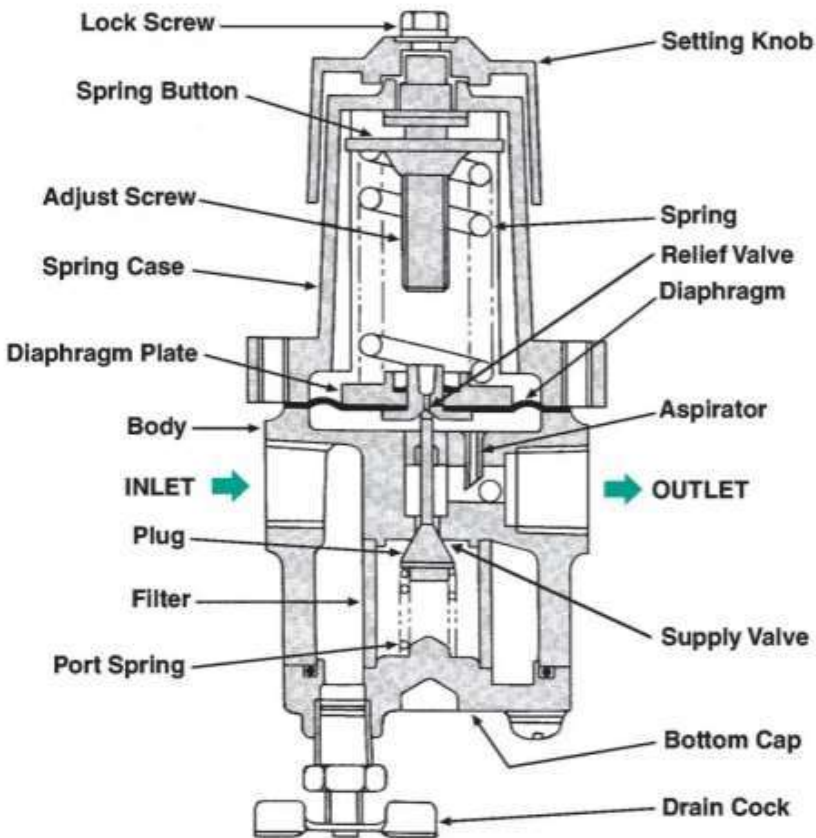

## Solenoid Valves:

- A solenoid valve is a combination of two basic functional units:
  1. Solenoid (electro-magnet) with its core (plunger).
  2. A valve containing an orifice in which a disc or plug is positioned to stop or allow flow.
- The valve is opened or closed by movement of the magnetic core which is drawn into a solenoid when the coil is energized.
- **Direct operated valve :**

In a direct operated valve the solenoid core is mechanically connected to the valve disc and directly opens / closes the orifice, dependent upon energization and de-energization of the solenoid.

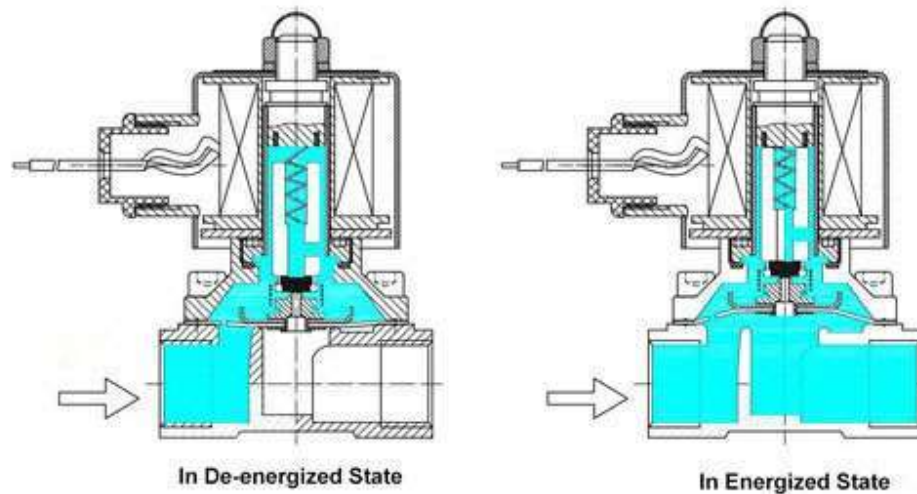

Figure - Direct Acting Solenoid Valve

- **Pilot operated valve :**

The pilot-operated solenoid valve is usually used in big diameter and high pressure occasions. As the valve is open, the minimum pressure of the solenoid valve is not allowed to be lower than 0.05MPa. So, the pilot pressure is required, otherwise it cannot be opened. In addition, the flow capability of the pilot-operated solenoid valve is bigger than that of the direct acting solenoid valve. It has a relatively higher requirement to the purity of the compressed air. Instead, the directly operated solenoid valve has no such high requirement.

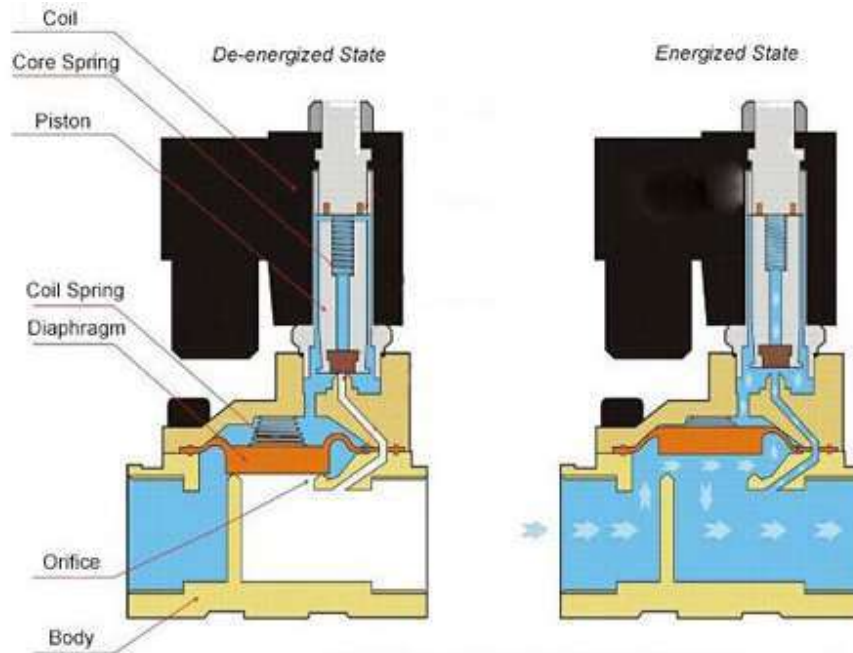

Figure - Pilot Operated Solenoid Valve

### Differences between pilot-operated and direct acting solenoid valve:

- **Pressure tolerance**  
The pilot-operated solenoid valve has a higher tolerance of liquid pressure than the direct acting solenoid valve.
- **Response time**  
The starting speed of the direct acting solenoid valve is quicker than that of the directly operated type. It is mostly used for the occasion of fast connection and disconnection. Because the small valve opens in the first and the main valve opens later when the pilot-operated solenoid valve is supplied with power. Instead, the directly operated solenoid valve is opened with its main valve directly. When the pilot-operated solenoid valve is energized, the small valve opens at the first and the main valve opens later. However, as to the direct acting solenoid valve, the main solenoid opens directly.
- **Flow capacity**  
The flow capacity of the pilot-operated solenoid valve is bigger than that of the directly operated type. Generally, the CV value can reach 3 or above. However, the directly operated solenoid valve usually has the CV value of below 1.
- **Power and consumption**  
The power and consumption of the directly operated solenoid valve are higher than that of the pilot-operated type.
- **Purity of the medium**  
The pilot-operated solenoid valve has a relatively high requirement to the purity of the flowing medium. However, the direct acting type has no such strict requirement.

## Types of Valves :

### 2/2 (2-Way Valves)

- It has one inlet and one outlet pipe connection.

#### -Normally Closed:

Valve is closed when deenergized and open when energized.

#### -Normally Open :

Valve is closed when energized and open when de-energized.

### 3/2 (3-WayValves)

- Three pipe connections and two orifices Used to alternately apply pressure to and exhaust from diaphragm.

#### - Normally closed

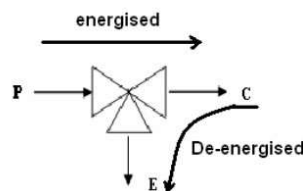

Normally closed

#### - Normally Open

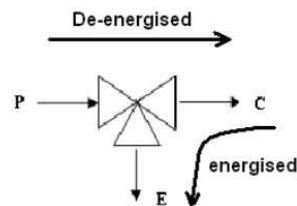

Normally open

### 4/2 and 5/2 (4-Way Valves)

- Four or five pipe connections one pressure, two cylinder and one or two exhausts.

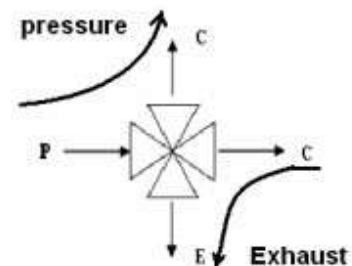

Energised

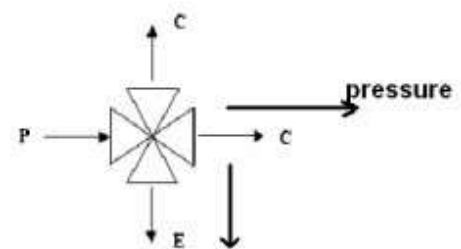

Exhaust

De-energised

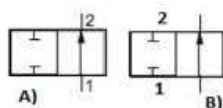

#### Number of Ports

#### Number of Positions

2/2 – Way directional control valve

A) Normally Open

B) Normally Closed

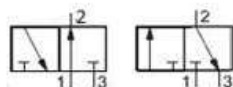

3/2 – Way directional control valve

A) Normally Open

B) Normally Closed

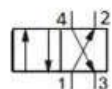

4/2 – Way directional control valve

Flow from 1 → 2 and from 4 → 3

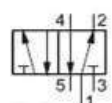

5/2 – Way directional control valve

Flow from 1 → 2 and von 4 → 5

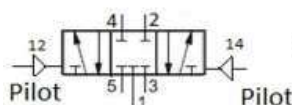

5/3 – Way directional control valve

Pilot Operated

Pressure Supply	1	P
Working Ports	2, 4	A, B
Exhaust Ports	5, 3	R, S
Ports Pilot Ports	12, 13	X, Y

## Air Lock Relay :

Air Lock valve is used to hold the operating air inside actuator chamber to not make any disturbance in valve opening when any Pneumatic air supply or source failure occurs in the air operated process control line.

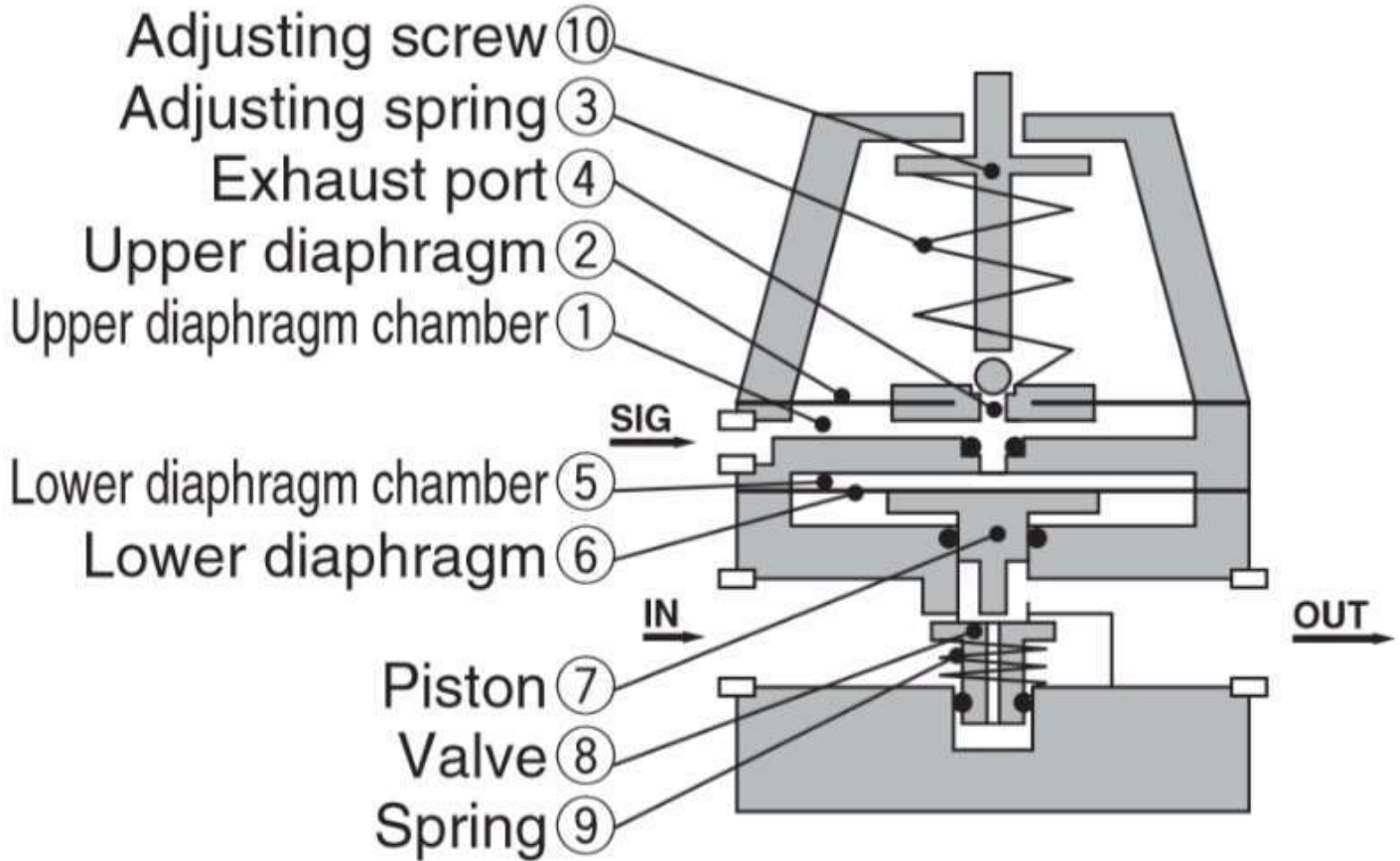

**Figure- Air Lock Relay/ Valve Inside View**

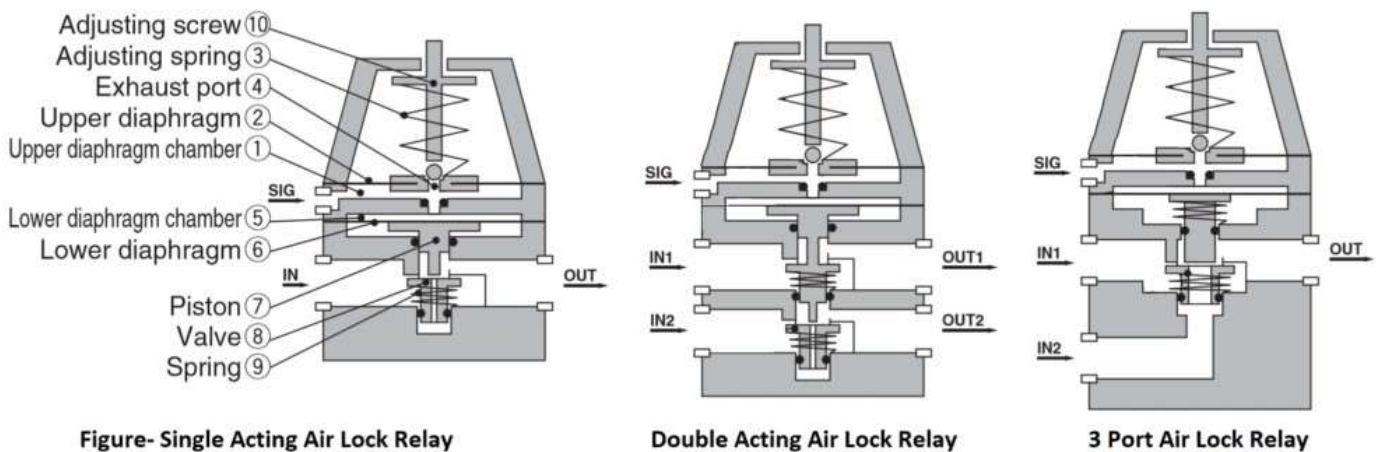
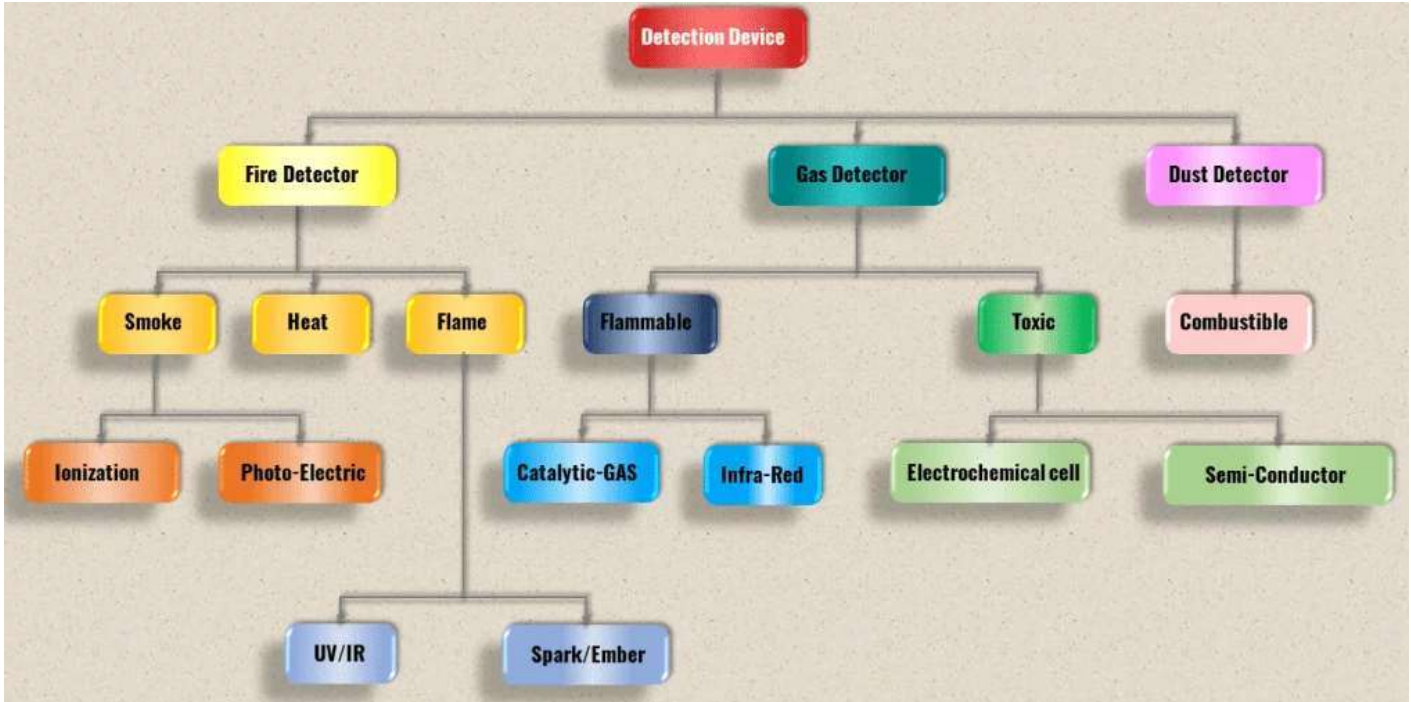

Figure- Single Acting Air Lock Relay

Double Acting Air Lock Relay

3 Port Air Lock Relay

## ⑧ Detection Device (Fire – Gas – Duct)



### Components of a Good Fire and Gas System:

A good F&G system combines innovative fire and gas detectors, conventional and analog addressable fire panels, clean agent and inert gas fire suppression systems, and a SIL 3-certified fire and gas logic solver into a consistently designed and executed solution. An integrated system provides common tools, operating interface, and networking, resulting in a common platform with independent systems.

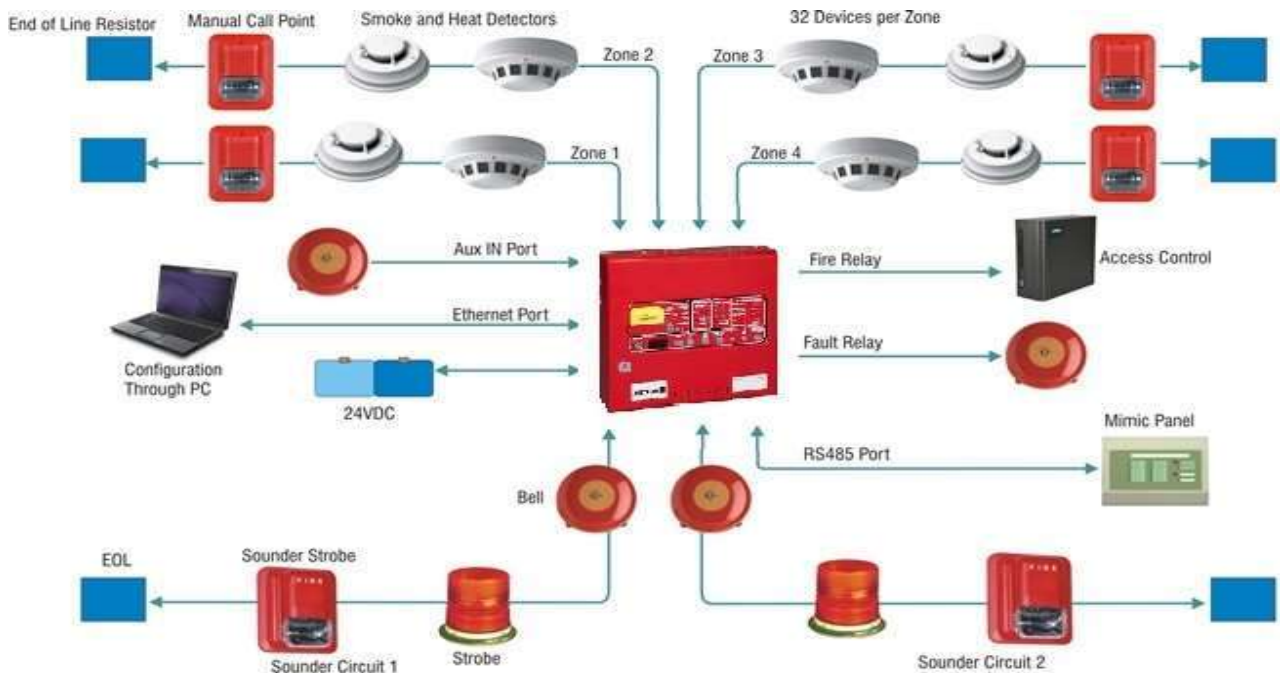

## Gas Detectors

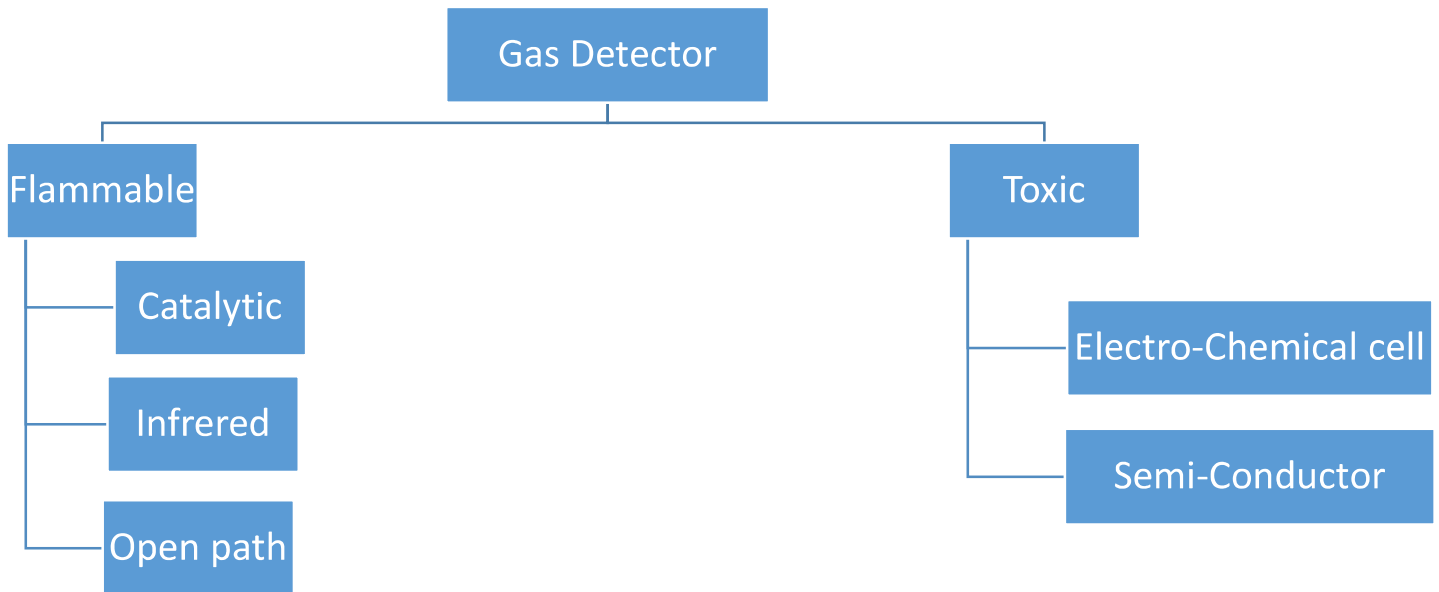

### Flammable Gas Detectors:

Detects the percentage by volume of flammable gas in air in terms of LFL (Lower Flammable Limit) and UFL (Upper Flammable Limit)



The three types of Flammable gas detectors are:

- Catalytic Gas Detectors
- Infrared Gas Detectors
- Open Path (Line of Sight) Gas Detectors

## Catalytic (Pellistor) Gas Detectors :

**Working Principle:** Catalytic gas detectors determine gas concentration through oxidization which results in heat, and this is sensed by a bridge circuit. It follows that catalytic gas detectors under-read in the low oxygen atmospheres which exist with gas-rich releases.

**Set Point:** Catalytic detectors have a typically recommended minimum alarm setting of 20 % LFL and 60 % LFL to indicate a low and high level of gas

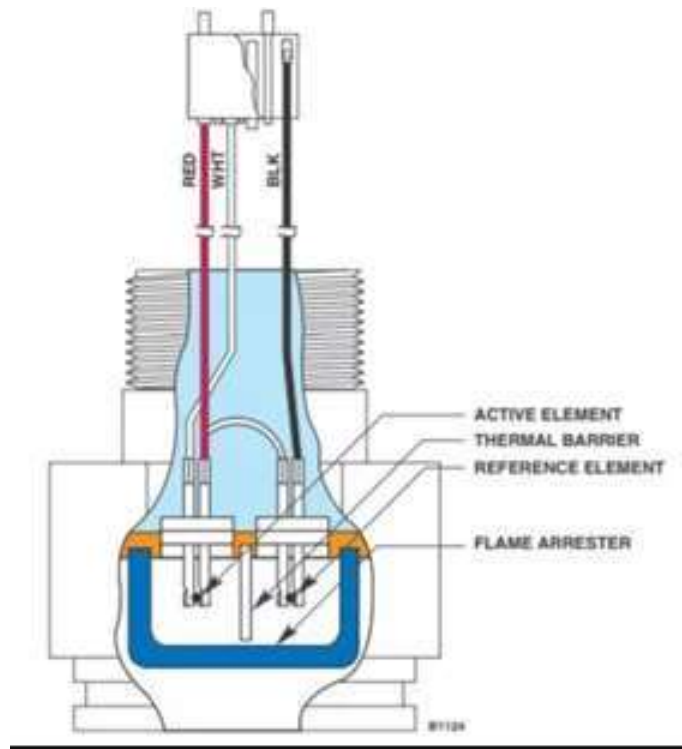

## Infrared Gas Detectors:

**Working Principle:** Infrared Gas Detectors make use of the property of Hydrocarbons and other gases to absorb infrared energy at certain wavelengths but not others. For HCs the absorption peak occurs around 3.4  $\mu\text{m}$ . A reference measurement is normally made close to the measurement wavelength that is not absorbed by expected gases. The ratio from the two measurements gives the gas concentration free from variations in signal intensity and detection sensitivity.

**Set Point:** Infra-red detectors have a typically recommended minimum alarm setting of 20 % LFL and 60 % LFL to indicate a low and high level of gas

## Open Path (Line of Sight) Gas Detectors:

**Working Principle:** Open path gas detectors make use of properties of gases to absorb infrared energy at certain wavelengths but not others. This property coupled with high energy sources enables open path detectors to sense gas over relatively long distances.

**Set Point:** Open path detectors have a typically recommended minimum alarm setting of 0.5 LFL m (50 % LFL extended for one meter)

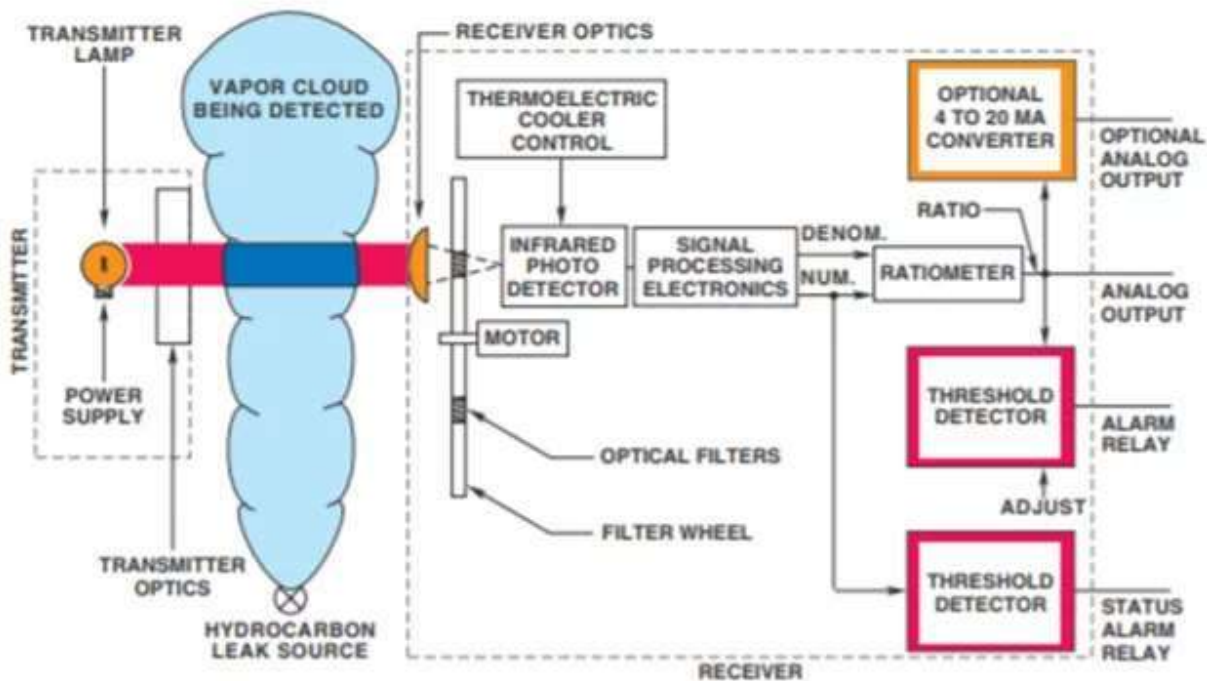

## Toxic Gas Detectors:

Detects the concentration in ppm of Toxic gas in terms of TLV (Threshold Limit Value)

Major 2 categories are available:

- Detectors for gases which create an immediate health hazard (eg. H<sub>2</sub>S, CO, HF, HCl, Cl<sub>2</sub>)
- Detectors for gases that create a health hazard on long term exposure (eg. Vinyl Chloride, Benzene, Toluene etc.)

## H<sub>2</sub>S detectors:

The two types of H<sub>2</sub>S detectors available are:

### Electro-chemical cell type:

This type is based on an electrochemical cell, developed to react exclusively to H<sub>2</sub>S. As a result of the chemical reaction of the cell organic electrolyte with H<sub>2</sub>S, an electric current is generated, which is proportional to the H<sub>2</sub>S concentration in the sample gas.

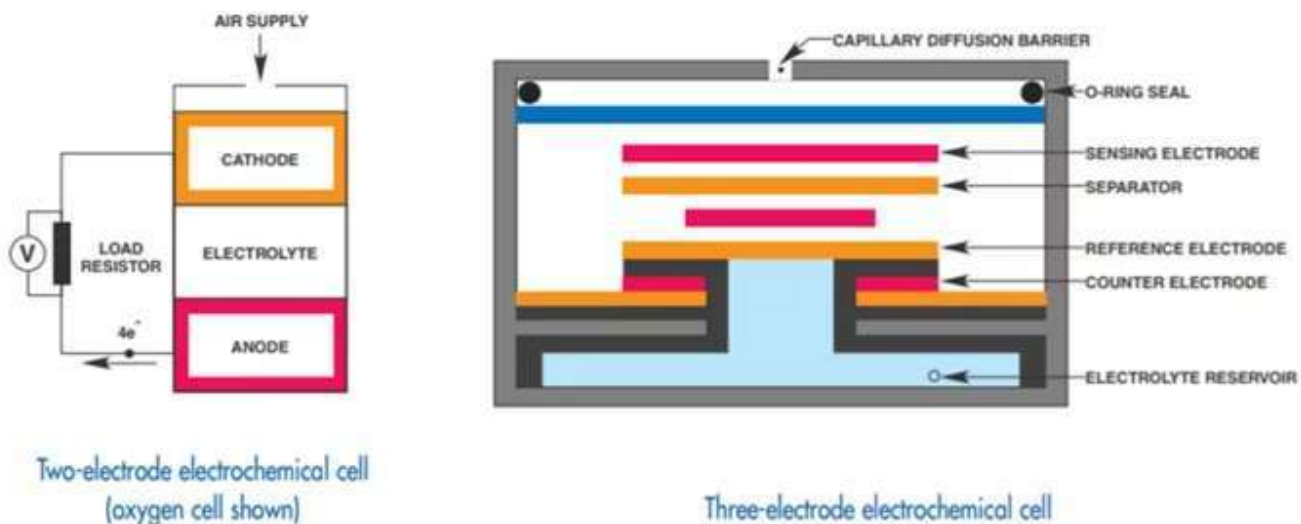

### Semi-conductor (MOS) type:

**Working principle:** The semi-conductor type is based on the adsorption of H<sub>2</sub>S molecules on the surface of a solid-state semiconductor crystal which causes a change in electrical resistance of the electrical circuit of which the semi-conductor forms the part.

**Set Point:** H<sub>2</sub>S detectors have a typically recommended minimum alarm setting of 5 ppm. If a second stage alarm is used, 10 ppm shall be used.

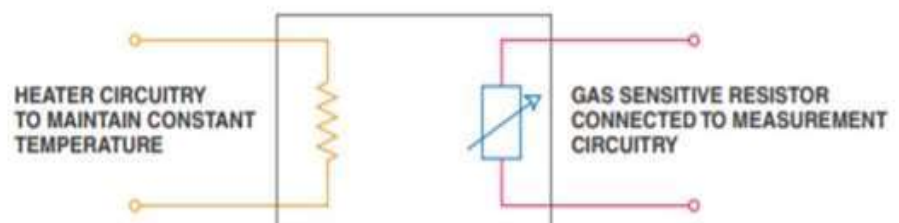

## Fire Detectors

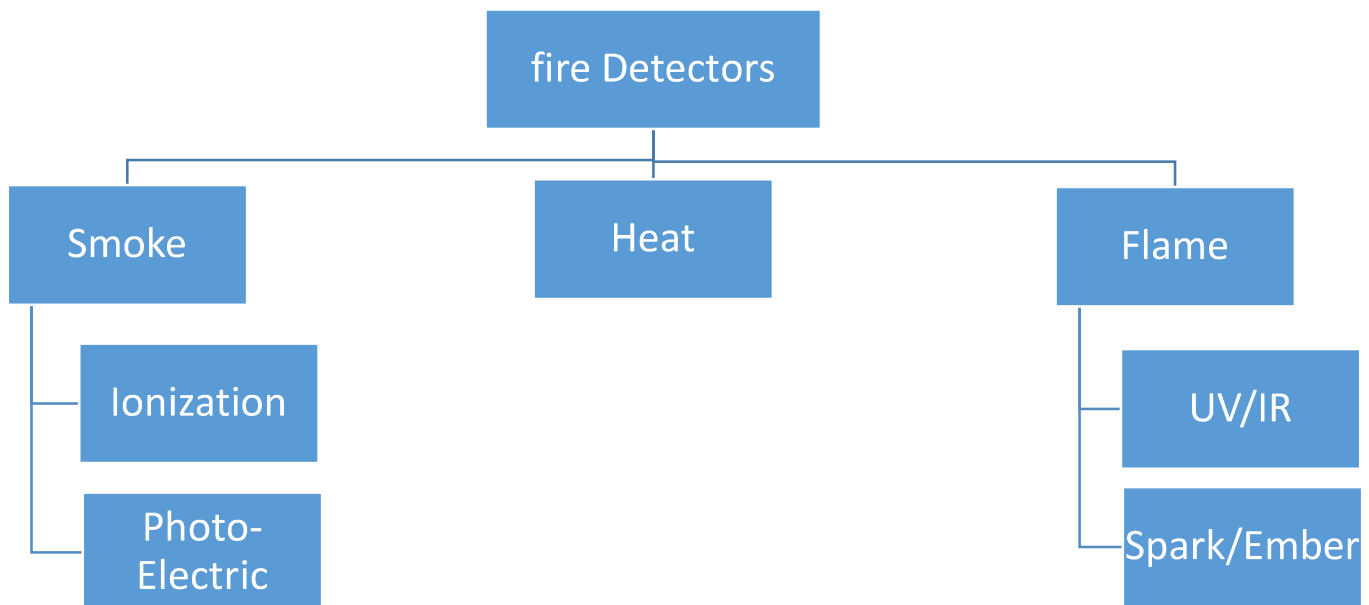

### 1. Smoke Detectors:

There are two types of smoke as mentioned above

#### **Ionization Smoke Detector**

##### **Detection Principle:**

These Detectors have an ionization chamber with an  $\alpha$  particle radiator consisting of an Americium-241 foil at its center and it ionizes the air inside the chamber.

An electric voltage is applied to the needle electrode and as a result, a known current flows through the detection chamber when the detector is in its normal state. In the event of a fire, minute aerosol particles (soot particles, combustion gases, etc.) attach themselves to the ionized particles. This increases the resistance in the chamber and consequently reduces the current flow within the detection chamber. This change is registered by Detector's electronics and a fire signal is sent to the Control Panel.

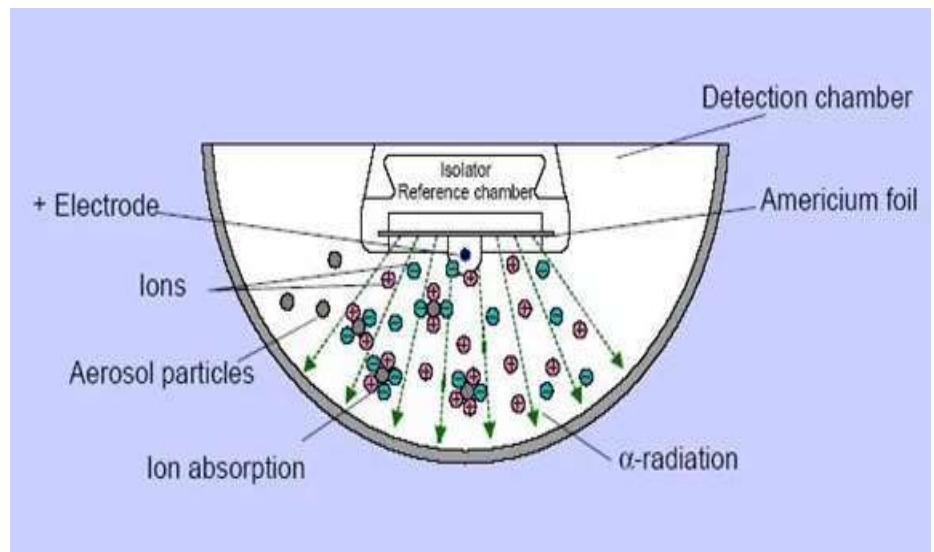

## Photo electric (Optical) Smoke Detector

### Detection Principle:

The sensor consists of a transmitter LED and a receiver photo-diode. These two devices are installed at a specific angle to one another and separated by a screen, so that light from the LED cannot impinge directly on the receiver diode.

The transmitter LED emits infrared light into the detection chamber. In the event of a fire, visible combustion products enter into the chamber and some of the light emitted by the LED is scattered by the particles so that it impinges on the receiver diode. This naturally increases the signal level generated by the receiver, which is registered by the detector electronics, which in turn triggers the alarm signal.

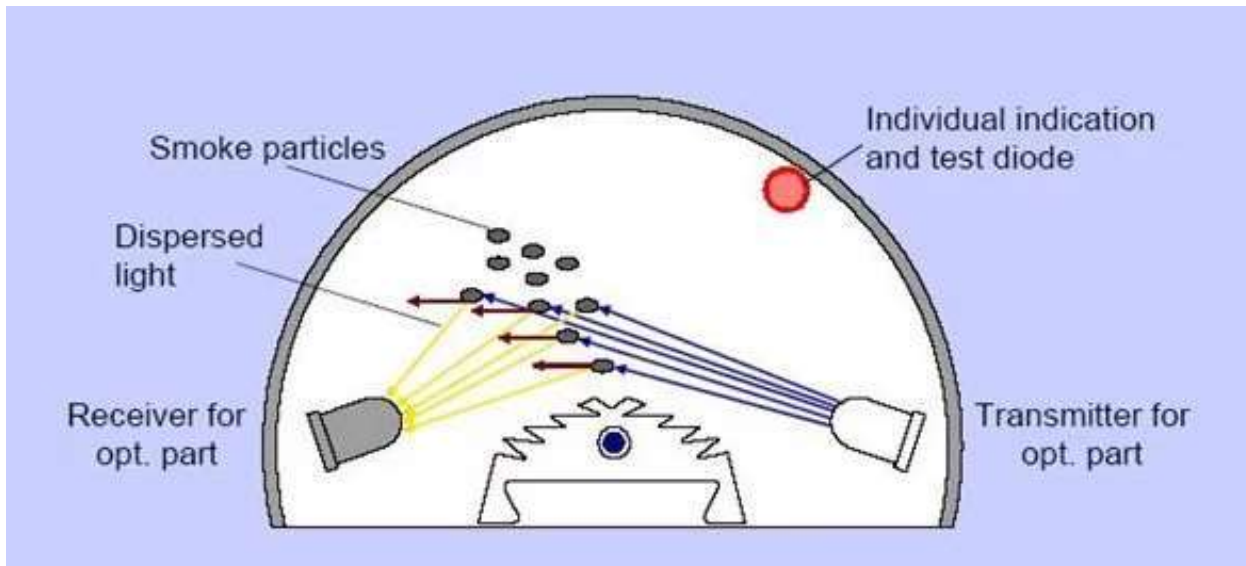

## **2. Heat Detectors:**

Heat or Thermal Detectors register the increase in temperature caused by a Fire.

### **Fixed Temperature**

It triggers automatically when a preset ambient temperature is reached.

### **Rate of Rise**

In addition to the present trigger temperature, the rate-of-rise detectors also evaluate the speed of temperature increase. If the temperature rises faster than the pre-set amount within a specific period, a rate-of-rise detector will trigger an alarm even if the set point trigger temperature has not actually been reached.

### **Rate Compensated**

It responds when the temperature of the air surrounding the device reaches a predetermined level, regardless of the rate of temperature rise.



### 3. Flame Detectors

- Flame detectors are typically used in open areas outdoors, but can also be used indoors
  - Used to protect high risk areas such as oil rigs, fuel stores, petro-chemical plants, hangers etc.
  - They work by analyzing the energy emissions from a fire (UV or IR) not the combustion products such as smoke and heat
  - Hot objects (engines / exhausts / heaters) are potential false alarm sources, including the Sun
  - Need to distinguish between emissions from a real fire and a false alarm source
  - High value detectors covering large areas
- The different types of Flame detectors are:

- Ultra Violet detectors
- Single Channel IR detectors
- Combined UV and Single channel IR
- Dual Channel IR flame detectors
- Triple Channel IR flame detectors
- CCTV flame detection



## Dust Monitors

Used to measure mass concentrations of dust, smoke, mists, and fumes in real-time, Thermo Electron dust monitors are widely recognized for their reliability, sensitivity, and long-term stability.

### Working principle

They are light scattering photometers (i.e., nephelometers) incorporating a pulse, high output, near-infrared light-emitting diode source, a silicon detector/hybrid preamplifier, and collimating optics, and a source reference feedback PIN silicon detector. The intensity of the light scattered over the forward angle of  $50^\circ$  to  $90^\circ$  by airborne particles passing through the sensing chamber is linearly proportional to their concentration. This optical configuration produces an optimal response to particles in the size range of  $0.1$  to  $10.0 \mu\text{m}$ , achieving a high correlation with standard gravimetric measurements of the respirable and thoracic fractions.

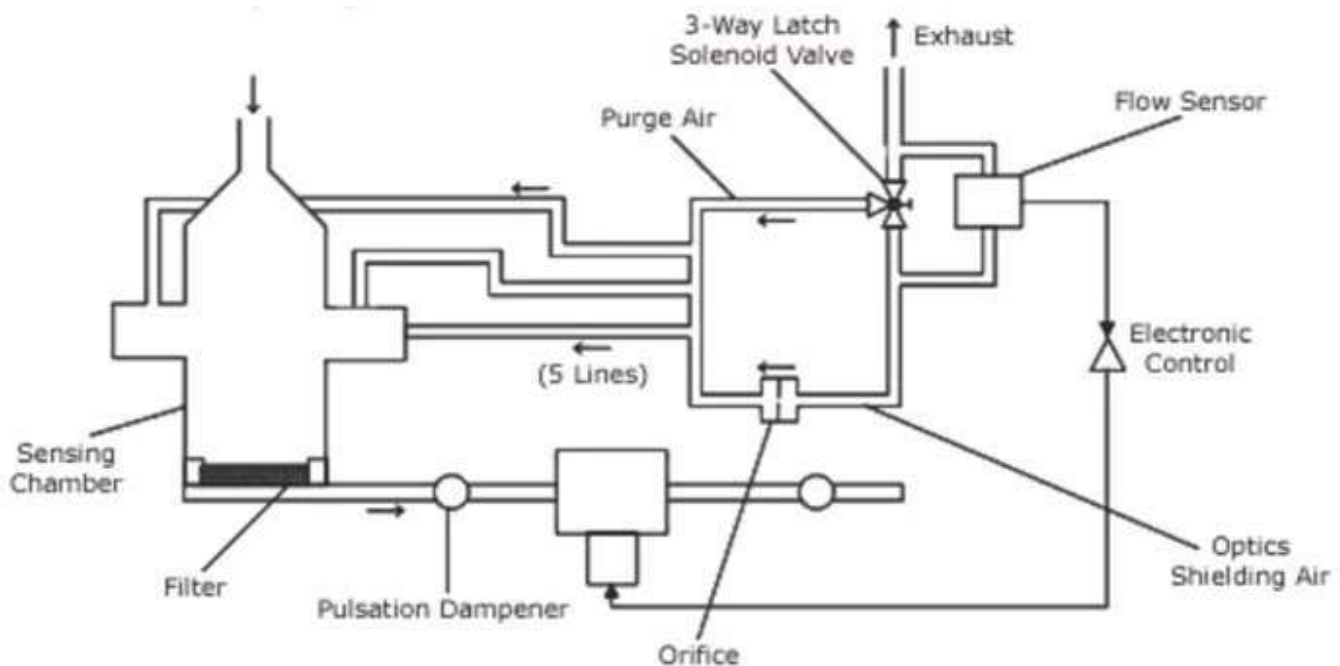

**The objective of Fire & Gas Detection system is to**

1. Minimize the risk and consequences of an accidental event.
2. Minimize the potential for hazardous occurrences
3. Ensure a safe working environment for personnel
4. Ensure adequate means of escape are provided
5. Provide sufficient safety devices and redundancy to detect, isolate and minimize uncontrolled releases of flammable and toxic liquids and gases.
6. Provide appropriate fire protection systems to rapidly bring under control and extinguish any reasonably foreseeable fire which could develop during normal operations.
7. Minimize the potential for pollution of the environment from accidental spills, venting or flaring of hazardous materials.

10